

Operating instructions

– Translation of the original operating instructions –

MPX dosing system

2026/03-V02



1005463	MPX SOLO 7-1 dosing system
1006090	MPX DUO 4-2 dosing system
1005472	MPX SMART 7-1 dosing system
1005478	MPX SMART 7-7 dosing system
1005477	MPX SMART 13-1 dosing system
1005479	MPX SMART 13-7 dosing system

Publishing details

SAIER Dosiertechnik GmbH
Gewerbestrasse 71
79194 Gundelfingen
Germany

Phone +49 761 59 25 20
Fax +49 761 58 49 09
Email info@saier.eu

Disclaimer

Diagrams and texts have been compiled with the greatest possible care. Nevertheless, errors and technical changes cannot be ruled out. The information is provided without guarantee.

Details in these operating instructions are subject to change without prior notice due to ongoing product development.

© 2026 SAIER Dosiertechnik GmbH

All rights, including photomechanical reproduction and storage in electronic media, reserved by SAIER Dosiertechnik GmbH.

Contents

1	Change index.....	3
2	Intended use	5
3	Disclaimer	5
4	EC/EU – Declaration of Conformity	6
5	About these instructions	7
6	Transportation and storage.....	9
7	Items supplied	9
8	Technical specifications.....	10
9	Description.....	12
9.1	The system.....	12
9.2	Components.....	13
10	Indicators and control elements	14
10.1	Display.....	14
10.2	Multiplexer	15
11	Installation.....	16
11.1	Installation location	16
11.2	Installation.....	16
11.3	Electrical installation	22
12	Operating modes	30
12.1	“APD” operating mode.....	30
12.2	“MPD” operating mode.....	33
12.3	“Direct” operating mode.....	36
13	Menu	37
13.1	Display.....	37
13.2	Menu structure	39

14	Startup	44
14.1	Calibration	46
15	Maintenance	48
15.1	Replacing the tube kit and the rotor	49
15.2	Replacing the tube	52
15.3	Check and clean the level rods	55
15.4	Descaling the level rods.....	55
15.5	Confirm and document maintenance work	56
15.6	Confirm and document maintenance tasks.....	57
16	Event log	58
16.1	Types of events.....	58
17	Faults	59
18	Replacement parts and support.....	61
19	Dismounting and disposal.....	62
20	Appendix	63

1 Change index

Date	Chapter	Reason for change	Amendment request
13.11.2025	1	Change index added	AE25144
13.11.2025	11.3	Updated or added <ul style="list-style-type: none"> • Connect SAIER router to MPX (optional) • Check the router Connection • Registering a device with a QR code in the SDDB web portal 	AE25144
13.11.2025	15.3	Chapter 'Checking and cleaning the level rods' added	AE25144
13.11.2025	17	Malfunction: Water overflow level control added	AE25144
13.11.2025	19	Disassembly and disposal – note added	AE25144
10.02.2025	15.3/4	Content adjustments made.	-
20.03.2026	11.2	<ul style="list-style-type: none"> • Connecting washing machine → à safety note added.. 	AE26035
	11.3	<ul style="list-style-type: none"> • Connecting washing machine with volt-free contacts → graphic revised. • Connecting control for dosing washing machine 1 contacts → graphic revised. • Connection options SD bus external → graphic revised. • Extending bus cable → newly created 	AE26035
	20	Note on the nameplate added	AE26035

2 Intended use

The SAIER MPX dosing system is intended exclusively for dosing multiple washing chemicals into one or more washing machines.

3 Disclaimer

Any other or additional use shall be considered improper use.

The manufacturer will not be held liable for resulting damage. Modifications to the peristaltic dosing pump are prohibited.

The dosing system may only be used in a technically faultless and operationally safe condition. Any improper use will result in extinguishment of the manufacturer's warranty and general liability.

This device must not be used by persons with physical disabilities, persons with reduced sensory or mental capabilities, or persons lacking experience and knowledge. Children must not use this device.

Only a qualified specialist may open the device. The dosing system must be installed by a trained specialist who is responsible for compliance with applicable standards and regulations.

Only accessories that have been tested together with this device and approved by SAIER Dosiertechnik GmbH may be used. If third-party accessories are used, SAIER Dosiertechnik does not guarantee that the device will operate or function safely or reliably.

There is no warranty for damage caused by using third-party accessories.

4 EC/EU – Declaration of Conformity

The company

HERBERT SAIER GMBH

Gewerbestr. 71

79194 Gundelfingen

Germany

hereby declares under its sole responsibility that the product referred to below is in conformity with the essential requirements of the following EC/EU Directives, harmonised standards and national standards.

Product:	MPX dosing system
Type:	MPX SOLO 7-1 dosing system MPX DUO 4-2 dosing system MPX SMART 7-1 dosing system MPX SMART 7-7 dosing system MPX SMART 13-1 dosing system MPX SMART 13-7 dosing system
EU Directives:	Machinery Directive 2006/42/EC Electromagnetic Compatibility (EMC) Directive 2014/30/EU Restriction of Hazardous Substances in Electrical and Electronic Equipment (RoHS) Directive 2011/65/EU
Harmonised standards:	EN 60335-1:2012+AC:2014+A11:2014 +A13:2017+A1:2019+A2:2019+A14:2019 EN IEC 61000-6-3:2021 EN IEC 61000-6-2:2019
Other standards used:	EN IEC 60335-2-41:2021+A11:2021

The protection objectives of the Low Voltage Directive 2014/35/EU have been met in accordance with Annex I, no. 1.5.1 of the Machinery Directive.

Herbert Saier GmbH
10 June 2024



Michael Saier
(Managing Director)

5 About these instructions



Important information

Read these operating instructions before using the device.

Please observe and comply with the following points:

- All instructions relating to the safety of the operator and protection of the surroundings must be followed.
- These operating instructions are considered an integral part of the device. They must be kept to hand and made available to relevant persons as required.
- These operating instructions must be precisely followed in order to use the device as intended and in the correct manner.
- All supplied technical information, care and maintenance instructions must be observed.

Safety information

Safety information is labelled according to the severity of the danger:



DANGER!

Indicates an immediate hazard with a high level of risk which may result in death or serious injury.



WARNING!

Indicates a hazard with a moderate level of risk which may result in death or serious injury.



CAUTION!

Indicates a hazard with a low level of risk which may result in minor or moderate injury or damage to property.

Types of hazard

The following types of hazard may arise during installation, operation, repair or disposal of the device:



Danger of death, electricity

Before opening the device housing, disconnect the power supply to the device and make sure it cannot be switched back on.



Crush hazard

Before operating the pump, ensure that all provided covers are properly fitted.



Chemical burn hazard

Wear eye protection.



Danger from chemicals

Wear protective gloves.



Danger from chemicals

Wear protective clothing.

Information notes

Information notes contain important instructions for the installation and proper operation of the device. They should always be observed.



Important information

This information note indicates that material damage or financial loss may occur if the information is ignored.



Information

This symbol indicates a helpful tip.

6 Transportation and storage





- Handle the device with care as it contains sensitive parts.
- Store the device in a dry and secure place.
- The storage temperature for the device should be between 10 °C and 45 °C.
- Store the device in its original packaging until ready for use.

7 Items supplied

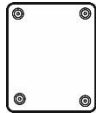

Check contents

Check delivery package contents against the delivery note immediately upon receipt of goods. Later complaints cannot be considered.

Quantity	Components	
1	MPX dosing system	
3	6 mm wall plug (screw anchor)	
3	Screws	
1	Drilling template	
3	Operating instructions DE / EN / FR	

8 Technical specifications

MPX SOLO

Performance data	Maximum flow rate:	350 ml/min
	Number of washing machines:	1
	Number of chemical products:	7
Electrical data	Operating voltage:	100 ... 230 V
	Frequency:	50 / 60 Hz
	Input power:	55 VA
	Control input voltage:	12 ... 240 V AC/DC
	Protection class:	IP24
Mechanical data	Dimensions W/H/D:	347 x 528 x 185 mm
	Weight:	5.2 kg
	Multiplexer tube connections:	8 mm internal diameter
	Pump tube connections:	8 mm internal diameter

MPX DUO

Performance data	Maximum flow rate:	350 ml/min
	Number of washing machines:	2
	Number of chemical products:	4
Electrical data	Operating voltage:	100 ... 230 V
	Frequency:	50 / 60 Hz
	Input power:	55 VA
	Control input voltage:	12 ... 240 V AC/DC
	Protection class:	IP24
Mechanical data	Dimensions W/H/D:	347 x 528 x 185 mm
	Weight:	6.2 kg
	Multiplexer tube connections:	8 mm internal diameter
	Pump tube connections:	8 mm internal diameter

MPX SMART

Performance data	Maximum flow rate:	1000 ml/min
	Number of washing machines:	Max. 7
	Number of chemical products:	Up to 13
Electrical data	Operating voltage:	100 ... 230 V
	Frequency:	50 / 60 Hz
	Input power:	69 VA
	Control input voltage:	12 ... 240 V AC/DC
	Protection class:	IP24
Mechanical data	Dimensions W/H/D:	520 x 610 x 210 mm
	Weight:	9.5 kg
	Multiplexer tube connections:	8 mm internal diameter

General data	Water supply pressure:	0.5 ... 6 bar
	Water temperature:	4 ... 40 °C
	Separation from potable water supply:	DIN EN 1717 cat. 5
	Suction height:	1.7 m
	Dosing programs:	80 dosing programs
	Program steps:	426 program steps
	Product dosings:	2304 product dosings
	Operating modes:	3 direct modes (1:1, sum, binary)
		APD mode (Automatic Program Detection)
		MPD mode (Manual Program Detection)
	Ambient temperature range:	+10 ... +40 °C
	Environmental stress:	Conforms to DIN EN 60068-2-38

Dimensions MPX SOLO and MPX DUO

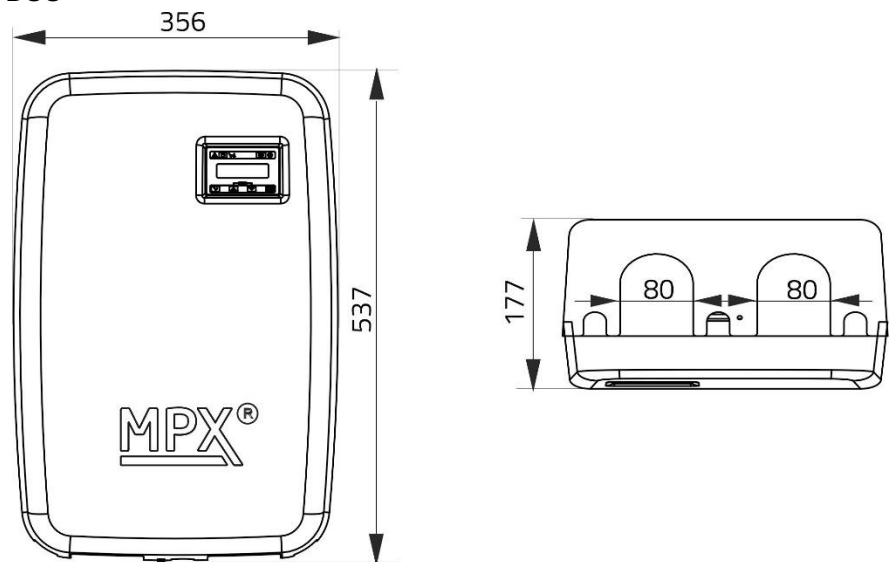

Dimensions Smart

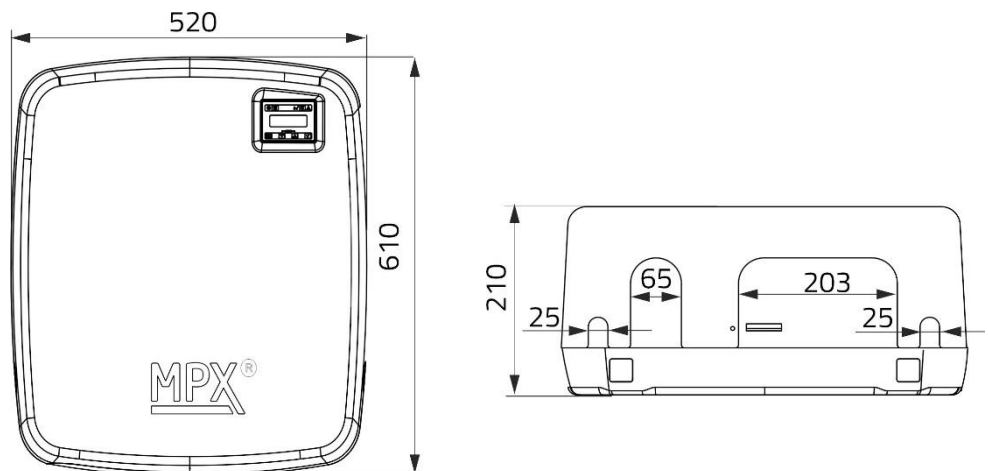

9 Description

The MPX dosing system doses several washing chemicals into one or more washing machines.

9.1 The system

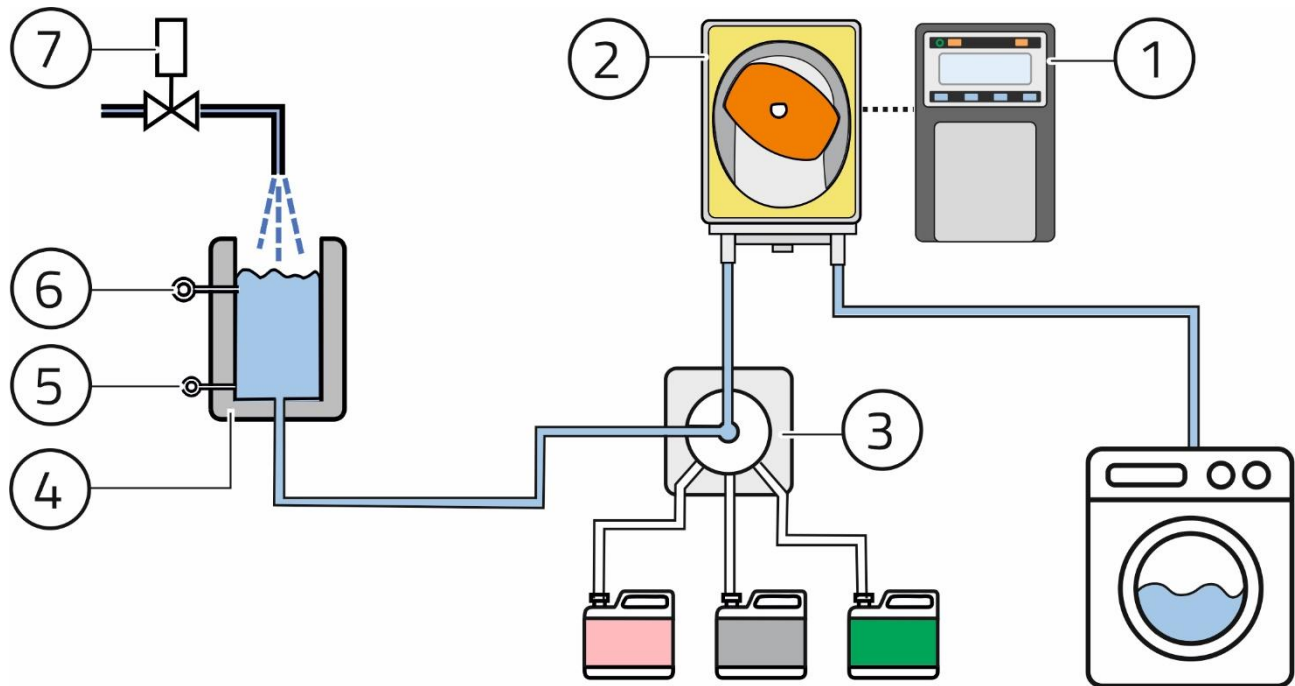

Figure 1: System

Item	Component	Function
1	Control unit	<ul style="list-style-type: none"> Controls the dosing pump Stores actions and faults
2	Dosing pump	Doses the washing chemical
3	MPX multiplexer	<ul style="list-style-type: none"> Opens the supply from the water reservoir Opens the supply of washing chemical Opens the supply to the washing machine
4	Flushing water reservoir	Holds water for flushing the lines
5	"Reservoir empty" sensor	Signals when there is no water in the reservoir
6	"Reservoir full" sensor	Signals when the reservoir is full
7	Solenoid valve	Supplies fresh water to the water reservoir

9.2 Components

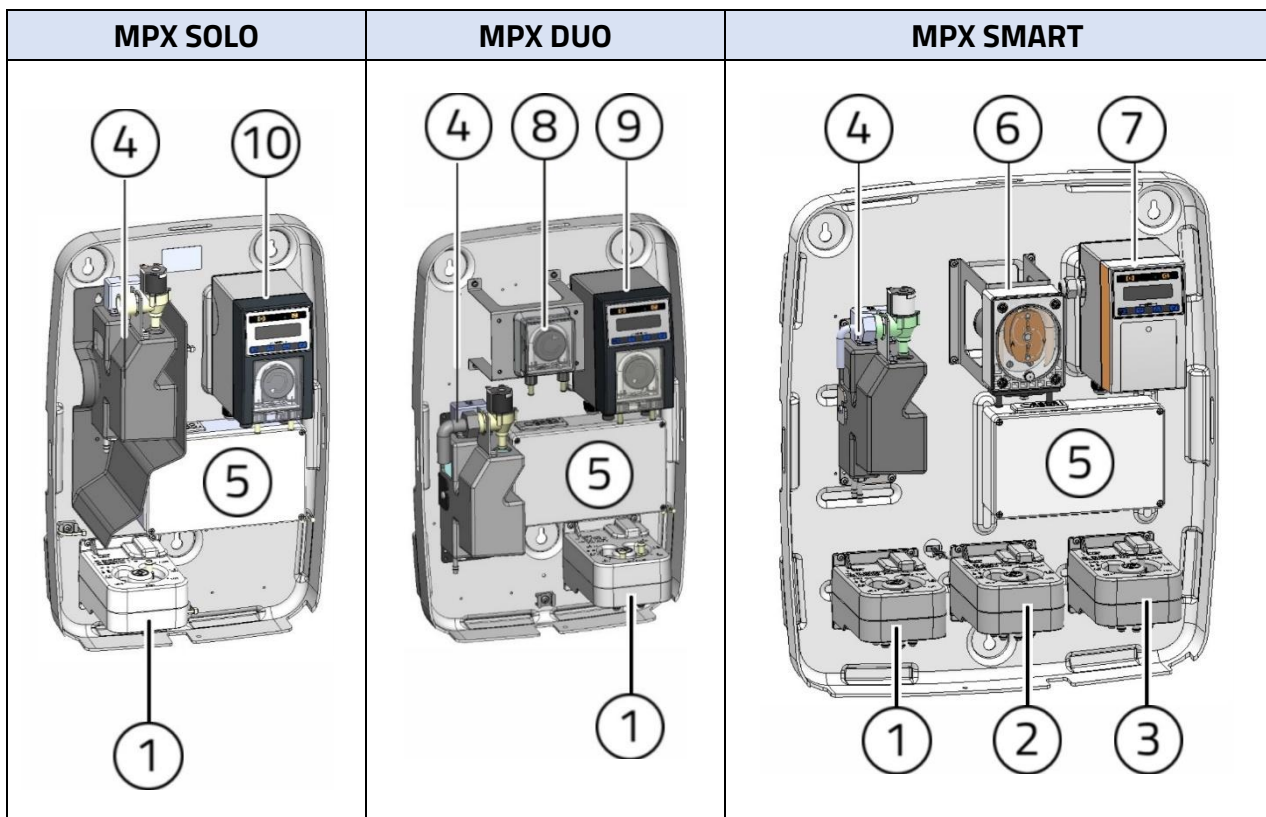

Figure 2: MPX dosing system components

- (1) MPX multiplexer 1 for washing chemical connection
- (2) MPX SMART multiplexer 2 for washing chemical connection
- (3) MPX SMART de-multiplexer for washing machines connection
- (4) Water reservoir with solenoid valve
- (5) Electrical connection box
- (6) MPX SMART dosing pump
- (7) MPX SMART control unit
- (8) MPX DUO dosing pump 1 for washing machine 1
- (9) MPX DUO dosing pump 2 for washing machine 2 with control unit
- (10) MPX SOLO dosing pump with control unit

10 Indicators and control elements

10.1 Display

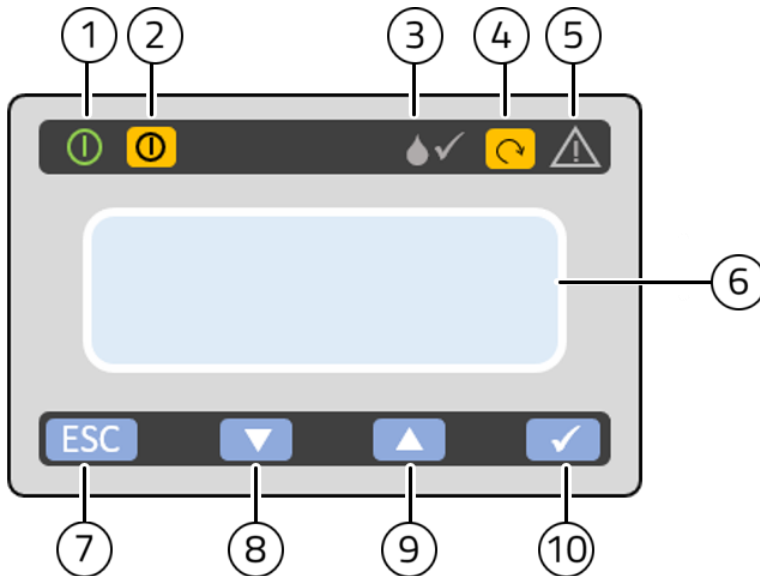







Figure 3: Control panel

Item	Description	Function
1	Operation indicator	Lights up green when operating voltage is present
2	"Operating mode" button 	Switch between operating modes: <ul style="list-style-type: none"> - MPX system activated - MPX system deactivated*
3	 indicator	Flashes when pump is running
4	 button	Manual filling for calibration and for purging air from a line
5	Fault indicator	LED lights up or flashes red if an error occurs
6	LCD display	<ul style="list-style-type: none"> - Displays menu text - Displays statuses
7	ESC button	<ul style="list-style-type: none"> - Cancel input - Back to last entry
8	 button	Decrease value
9	 button	Increase value
10	 button	<ul style="list-style-type: none"> - Display status of control inputs - Confirm input in the menu - Continue to next menu item

* In the "MPX system deactivated" operating mode, operations can be carried out manually via the menu. In this mode, the "Fault" indicator flashes.

Status of control inputs

After pressing the button, the "control inputs status" display appears:

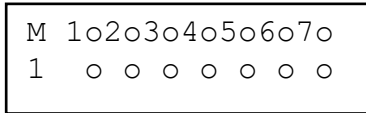

The first column shows the number of the machine. The status of the control inputs is shown in the other columns.

○ = control input off

● = control input on

The statuses of the other washing machines can be viewed using the and buttons.

LED signals

LED	Signal	Meaning
Green	Lights up continuously	Dosing not active Setpoint value reached
Green	Flashing at normal speed	Dosing active Setpoint value not reached Pump is running
Red	Lights up continuously	Tube rupture detected
Red	Flashing at normal speed	Suction lance empty signal
Red	Flashing rapidly	Maximum dosing time exceeded (container empty or other fault)

10.2 Multiplexer

Multiplexer indicator

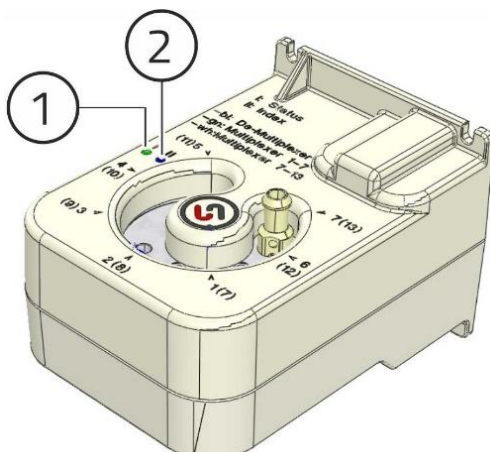

(1) Status indicator

- Green continuous: Valve is in target position.
- Green flashing: Valve moving to target position.
- Red flashing: Fault.

(2) Operating mode indicator

- Green: Multiplexer 1
- White: Multiplexer 2
- Blue: De-multiplexer



11 Installation

11.1 Installation location

- An installation location should be chosen that is not exposed to humidity, water, vapours, alkalis, acids or extreme hot or cold temperatures.
- The mounting surface should be flat and distortion-free.
- The mounting surface should be free of vibrations and shocks.
- The pump must be installed above the level of the container.

11.2 Installation

Removing the MPX cover

<p>▶ Unscrew the screw on the underside of the device.</p>	
<p>▶ Using both hands, grip under the cover in the middle of the device.</p> <p>▶ Pull the cover apart slightly.</p>	
<p>▶ Pull the cover slightly forwards.</p>	

<ul style="list-style-type: none"> ▶ Lift the cover upwards. ▶ Remove the cover. 	
--	---

Mounting the device

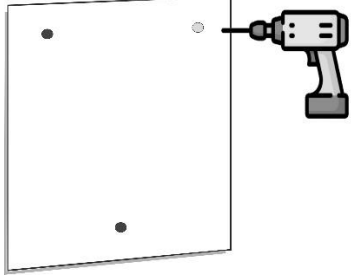
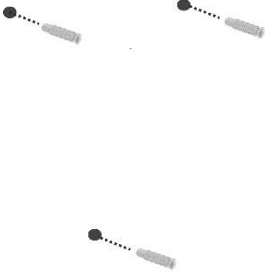
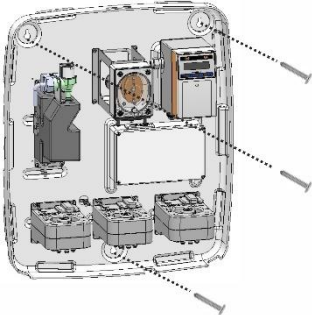
<ul style="list-style-type: none"> ▶ Hold the drilling template against the wall. ▶ Drill the three mounting holes. 	
<ul style="list-style-type: none"> ▶ Insert the wall plugs (screw anchors) into the holes. 	
<ul style="list-style-type: none"> ▶ Mount the device with the screws. 	

Fresh water connection

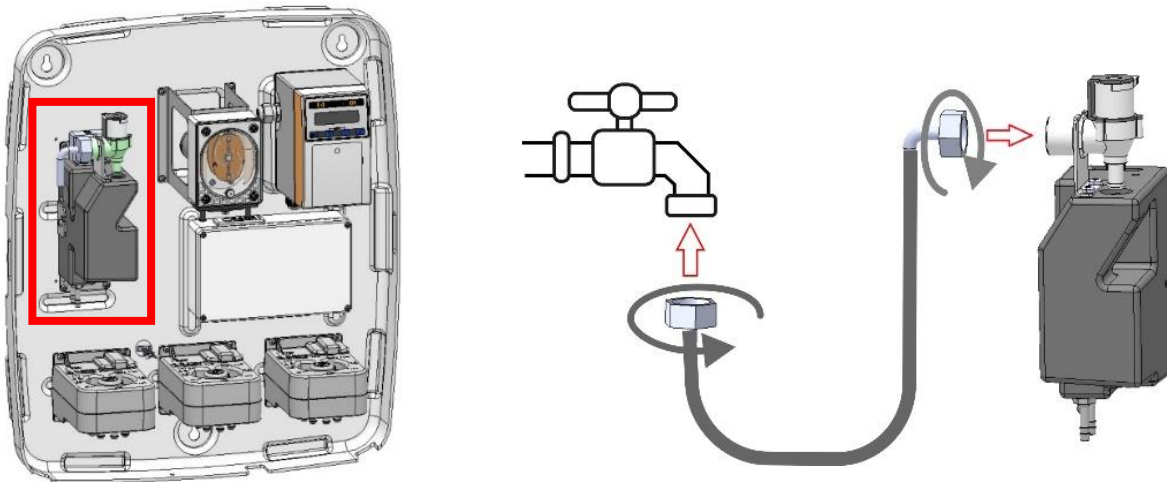

- ▶ Connect the water hose to the tap.
- ▶ Connect the water hose to the MPX water tank.





IMPORTANT INFORMATION

The pipes and hoses used for the water supply must conform to local regulations!

Connecting the washing chemicals

The lines from the washing chemicals are connected to the multiplexer and secured with hose clamps.

 WARNING	
 	<p>Chemical reaction due to unsuitable hose and connection materials.</p> <p>Toxic vapours, smoke or chemical leakage possible.</p> <p>Severe chemical burns, poisoning, fire and material damage possible.</p> <ul style="list-style-type: none"> • Check media compatibility of all parts in contact with media (SDS/resistance). • Use only approved hoses, seals and connectors. • Do not use universal hoses without verification. • In case of bubbles, odour or smoke: Stop the system and depressurise it. • Evacuate and ventilate the hazard area. • Eliminate the cause before restarting.

Material recommendation for parts in contact with media

The choice of material depends on the dosing medium, its concentration and the temperature. This recommendation applies to all parts in contact with media. These include hoses, seals and connectors between the dosing system and washing machine.

- **Preferred plastics:** PTFE, PVDF, PP, PE-HD.
- **Metals:** only after chemical approval, e.g. highly alloyed steels or special materials.
- **PVC:** only use if proof of resistance is available for the dosing medium.

Connect the lines from the washing chemicals to the multiplexer and secure with hose clips.

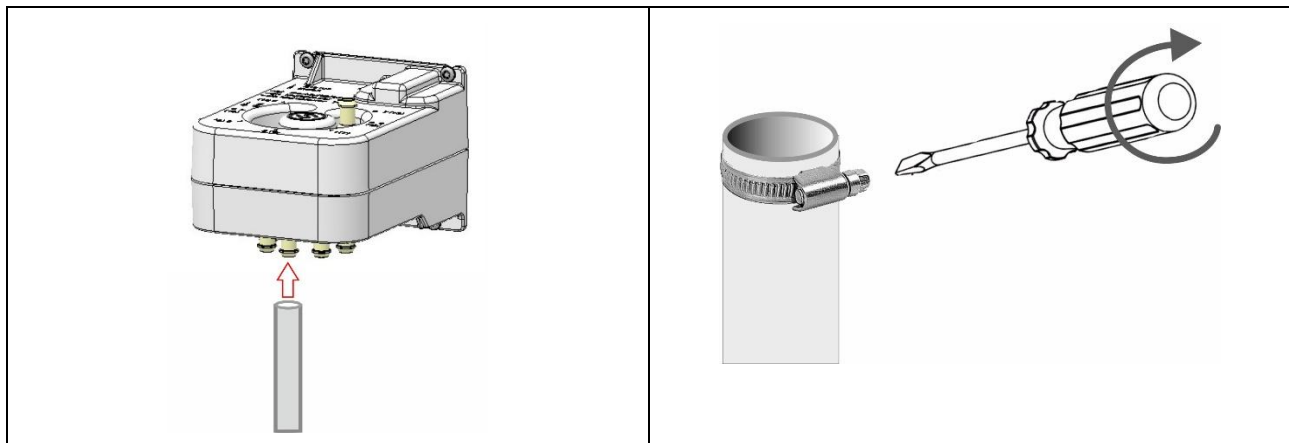

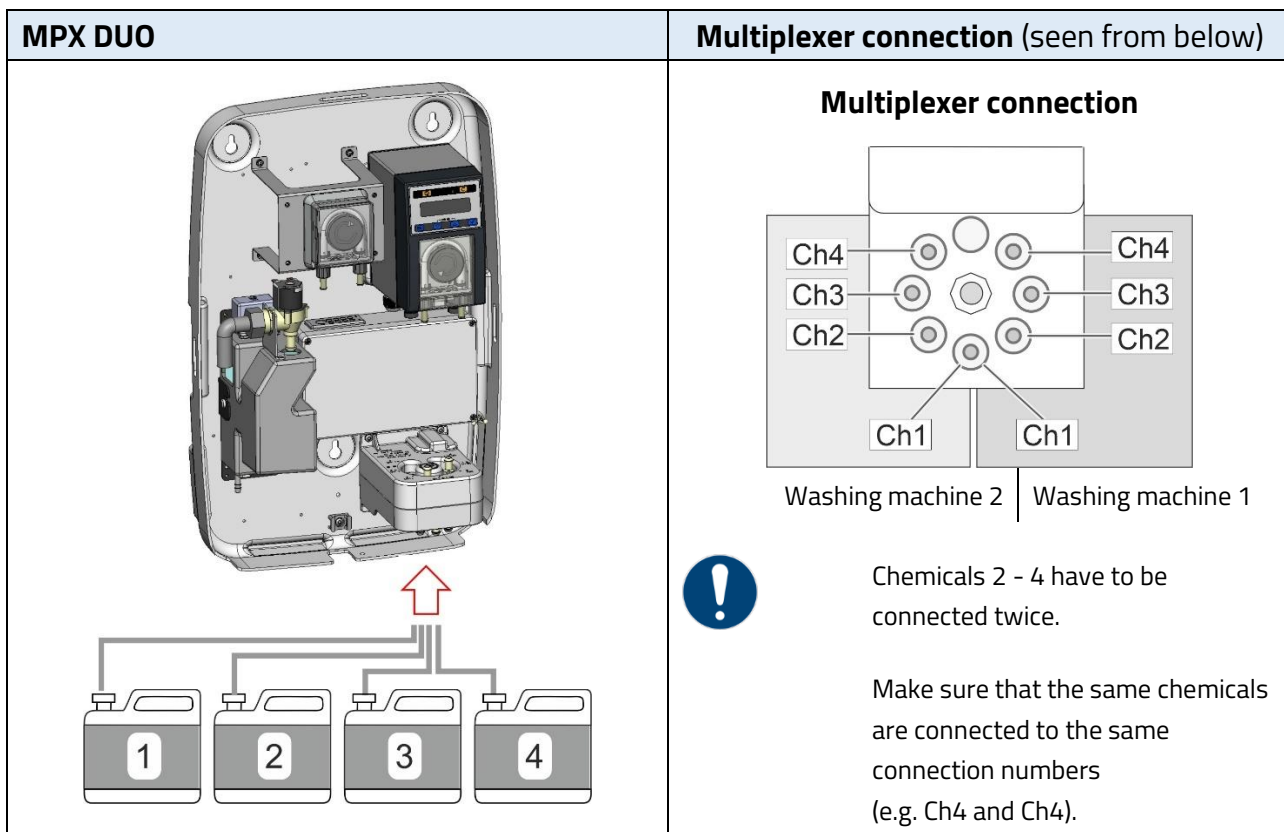
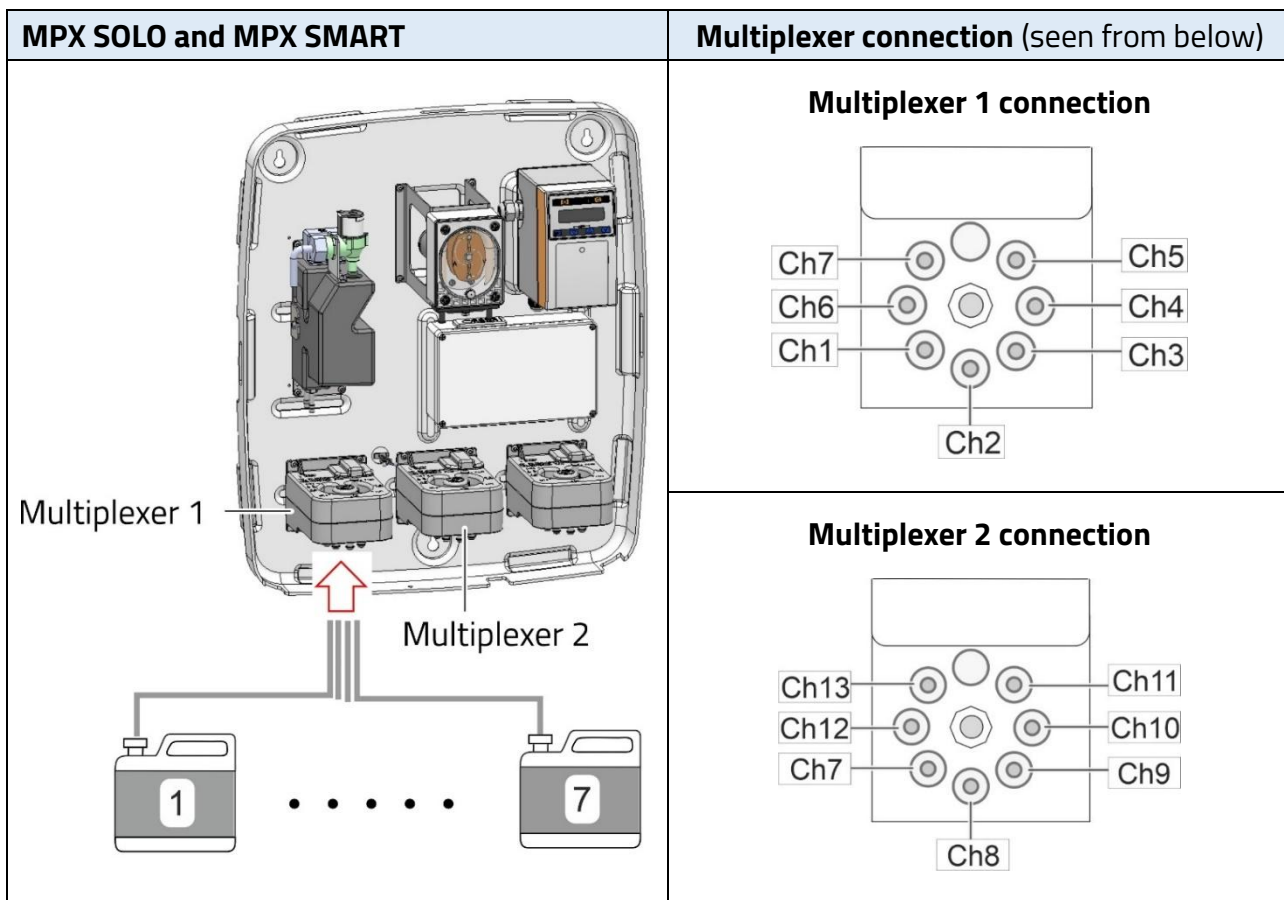

Connecting the washing machine

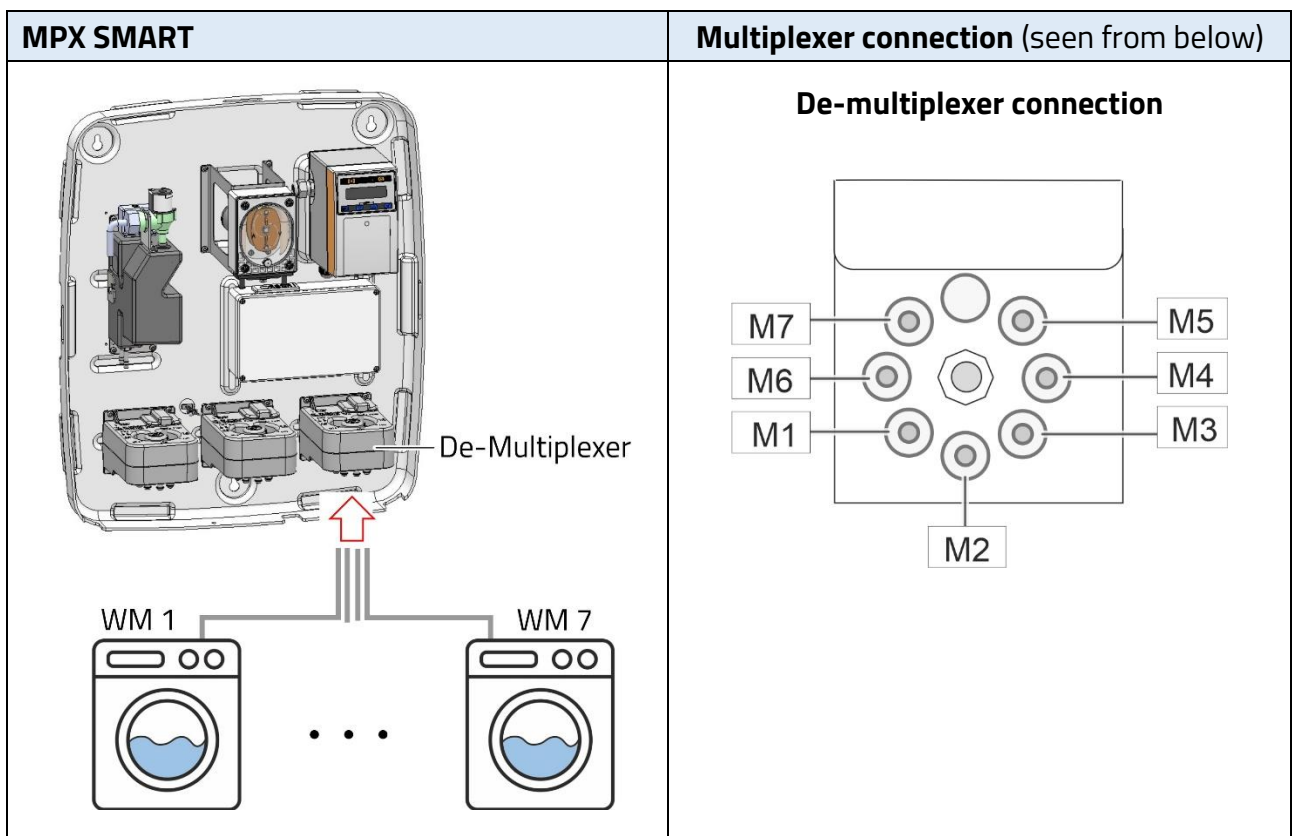
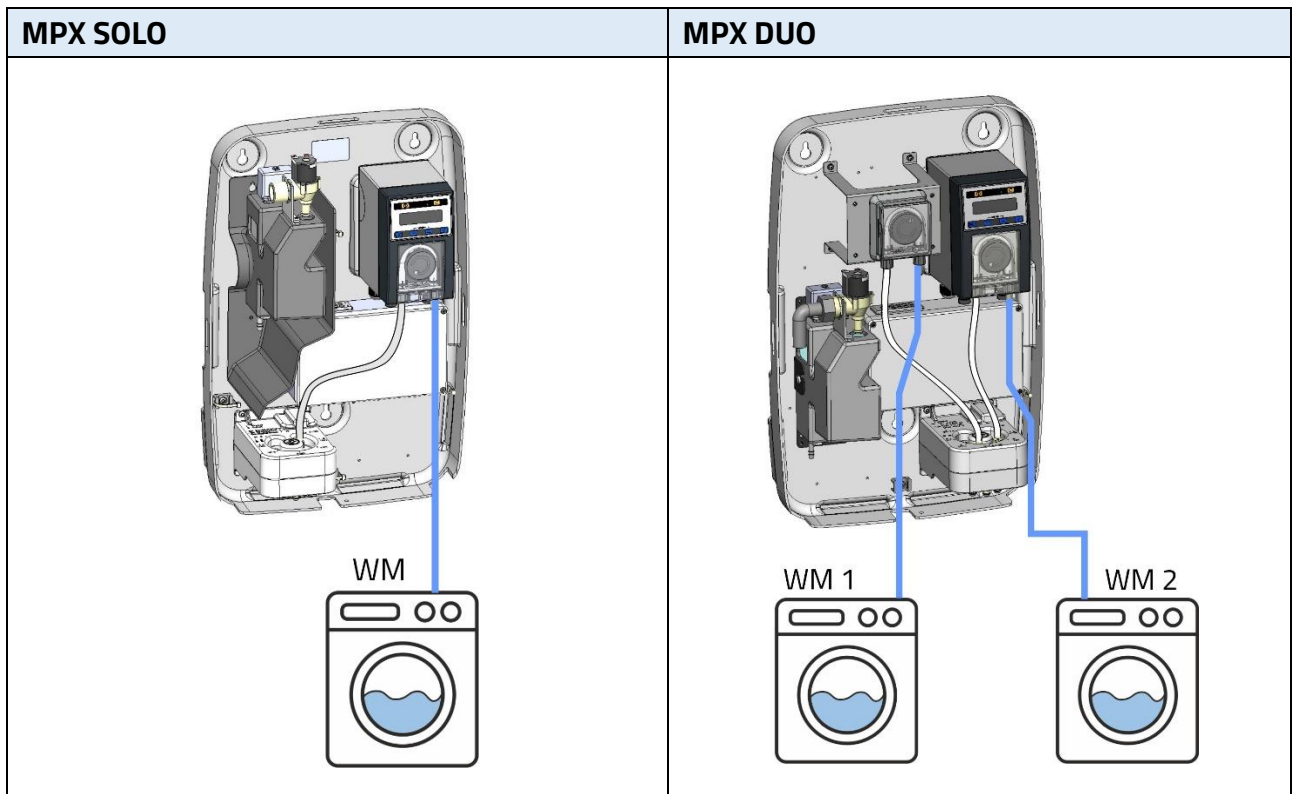

11.3 Electrical installation



Danger of death, electricity

Before opening the device housing, disconnect the power supply to the device and make sure it cannot be switched back on.



Important information

- The electrical installation may only be carried out by an authorised electrician.

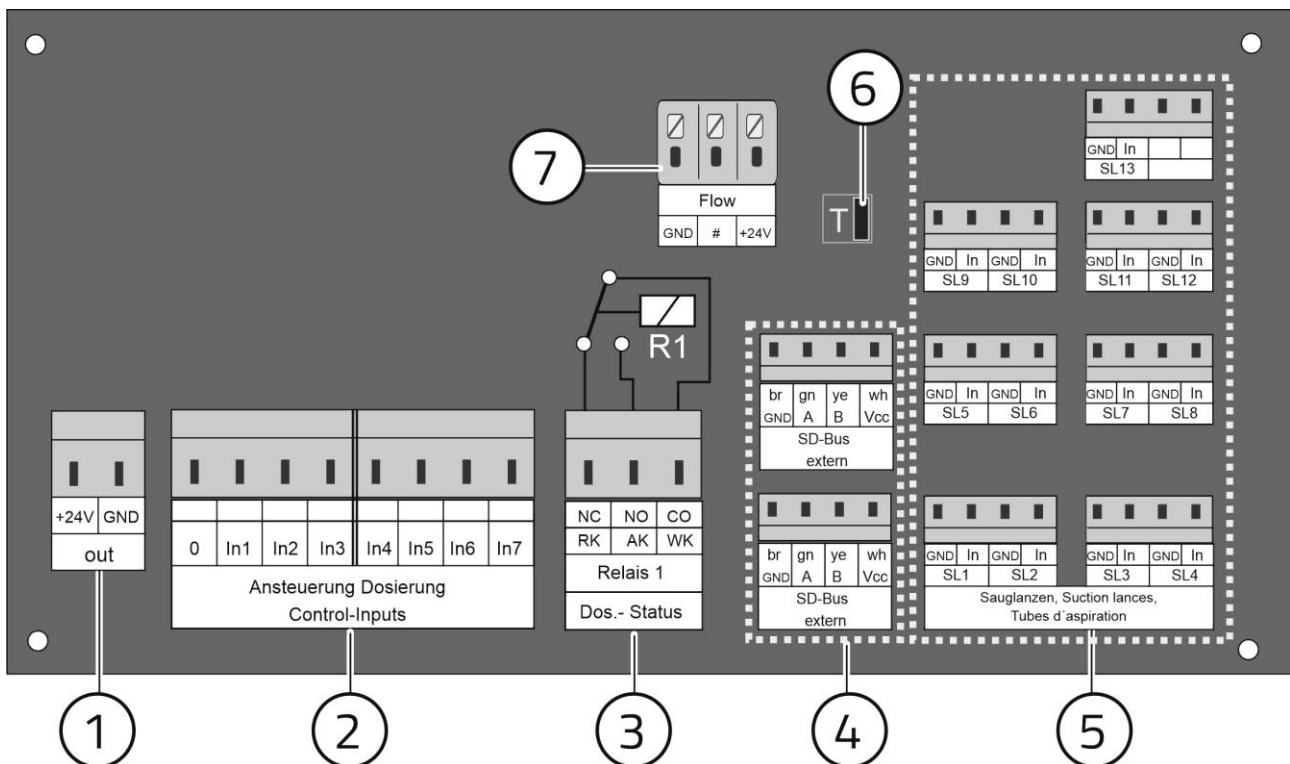

Figure 4: MPX connection board

- (1) Connection 24 V DC output (max. 20 mA)
- (2) Connection for dosing control
- (3) Stop signal connection (stop signal to the washing machine)
 Connection WK and AK = normally open contact (NO)
 Connection WK and RK = normally closed contact (NC)
- (4) 2 SD bus external connections
- (5) 13 suction lance connections
- (6) T-jumper (terminating jumper)
- (7) Flow meter connection (no function with this firmware)

Mains power connection

The supply voltage is connected via the pre-fitted Europlug.

Connection of washing machine with volt-free contacts

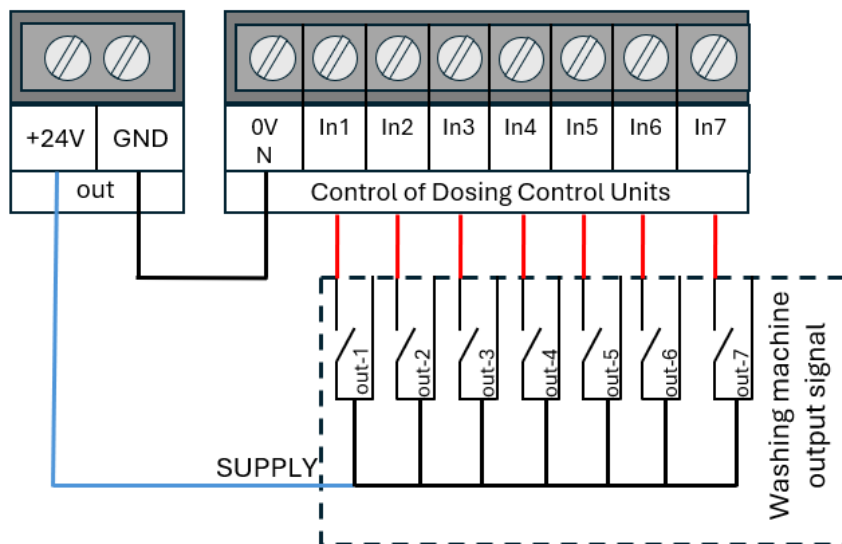

24 V DC control voltage for washing machine 1. The control signals for dosing are sent from the washing machine to the MPX **via volt-free normally-open contacts**.

Connection for dosing control washing machine 1

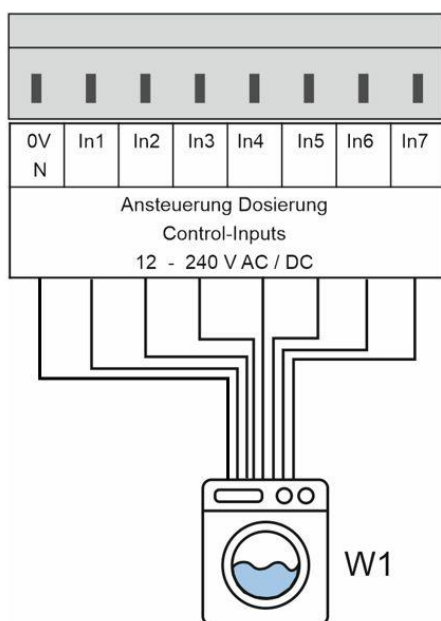

The control lines from washing machine 1 for dosing control are connected to terminals In1 – In7.

- i Terminals In1 – In7 must be connected according to the selected operating mode (see section 12 “Operating modes”).
- i MPX I/O modules are required in order to operate additional washing machines with the MPX dosing system.

SD bus external connection

	Device damage!
	Incorrect connection of the bus causes permanent or intermittent malfunction!

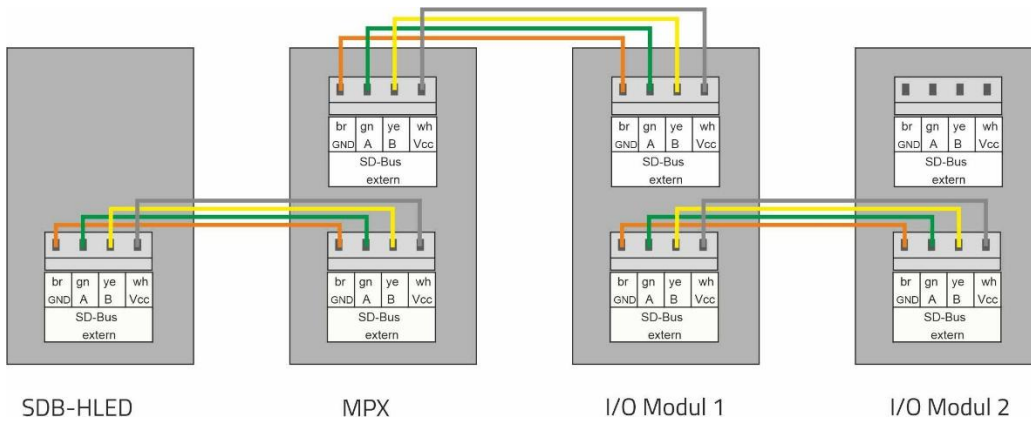

Bus termination

The SDB-HLED flashing warning light is a terminating device and should be connected at the beginning or end of the bus. This means that only the other end of the bus needs to be terminated.

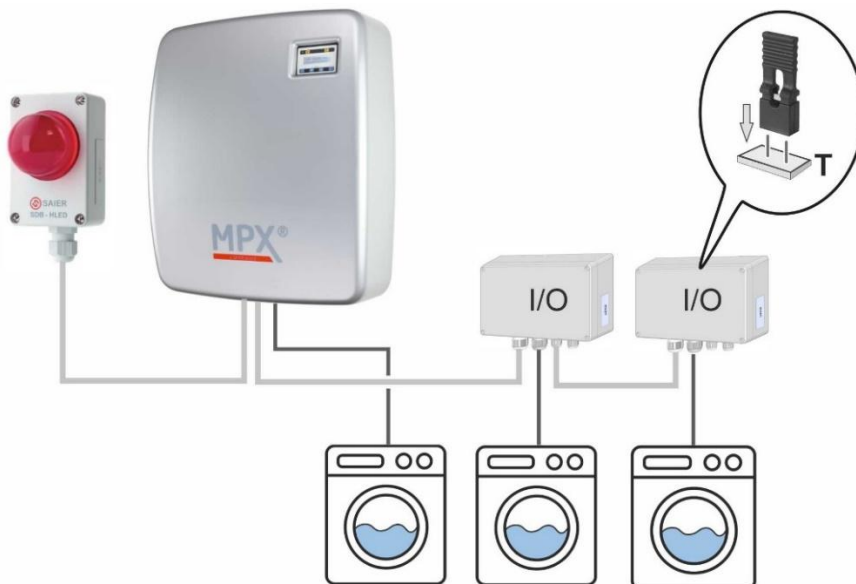

Set T-jumpers correctly!

If a flashing warning light is connected to the MPX, the T-jumper (terminating jumper) in the MPX must be taken out. A T-jumper must be fitted in the last I/O module on the bus.

If a program selector is connected at the end of the bus, the terminating resistor must be plugged in.

SD bus external connection options

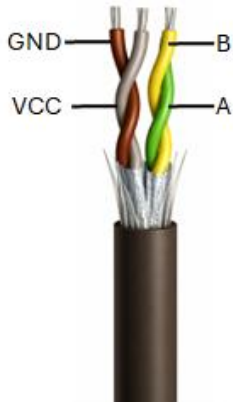

For use, we recommend our SAIER bus cable.

Requirements for the bus cable

- Core structure: 2 × 2 cores, twisted in pairs
- Conductor cross-section per core: 0.25 ... 0.50 mm² (≈ AWG 23 ... 20)
- Core pairs: A/B and GND/VCC

The following components can be connected externally to the SD bus.



- **MPX program selector**

The MPX program selector is used to select and start dosing programs for a washing machine.

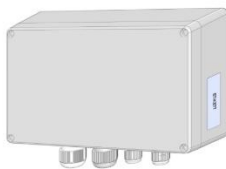

- **MPX I/O module**

MPX I/O modules can be used to connect up to six additional washing machines to the MPX dosing station.

Except for washing machine 1, an I/O box is required for each washing machine.

(For details, see instructions for MPX I/O module).



- **Flashing warning light SDB-HLED**

The SDB-HLED flashing warning light signals faults visually (lamp) and acoustically (warning tone).

 The flashing warning light has only one SD bus connection. This device must be the first device in the SD bus (see illustration on next page).

Suction lance connection

[Four black rectangular indicators]			
GND	In	GND	In
SL1		SL2	

Thirteen suction lances can be connected to terminals SL1 – SL13 on the connection board.



The suction lance inputs are factory-set for normally open contacts (switch closes when the container is empty).

Connect SAIER router to MPX (optional)



Important information

- The LTE router may only be installed in a dry room.
- Make a note of the SERIAL number and IMEI number on the back of the router. These are required for support.
- Do not reset the router to factory settings!

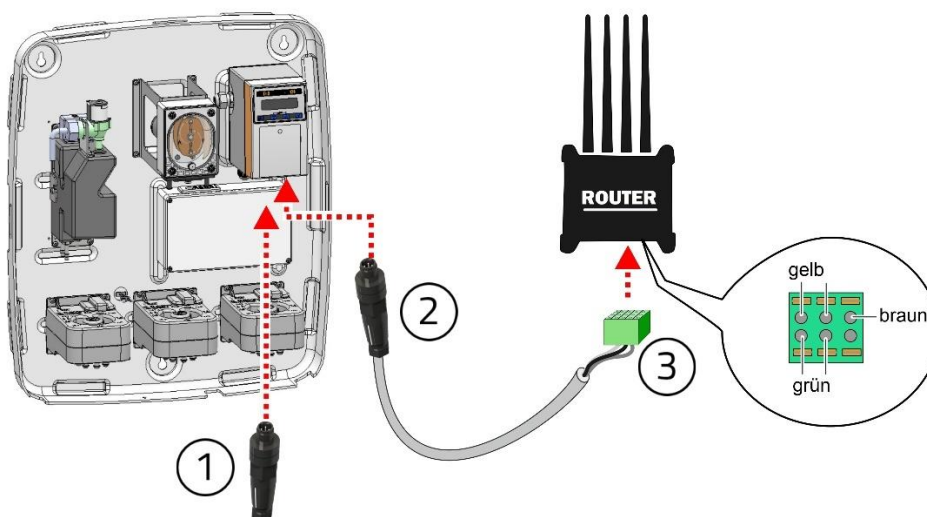

1. Plug the terminating resistor (1) into the left socket on the control unit.
2. Plug the router cable plug connector (2) into the right socket on the control unit.
3. Plug the connection terminal on the router cable (3) into the router.

Extending the bus cable



Important information!

Incorrect connection of the BUS can cause a permanent or occasional malfunction.

Connect and terminate the bus correctly. Extension of the BUS cable is possible up to a **total length of 50 m**.

Specifications for extension

- Carry out the extension only on the **M12 connector**.
- White conductor remains **not connected**.
- Maintain twisting of the core pairs up to the connector.
- After extension, check and set BUS termination.

Requirements for the bus cable

- Core structure: 2 × 2 cores, twisted in pairs
- Conductor cross-section per core: 0.25 ... 0.50 mm² (≈ AWG 23 ... 20)
- Core pairs: A/B and GND/VCC

Connect multiple MPX to SAIER router

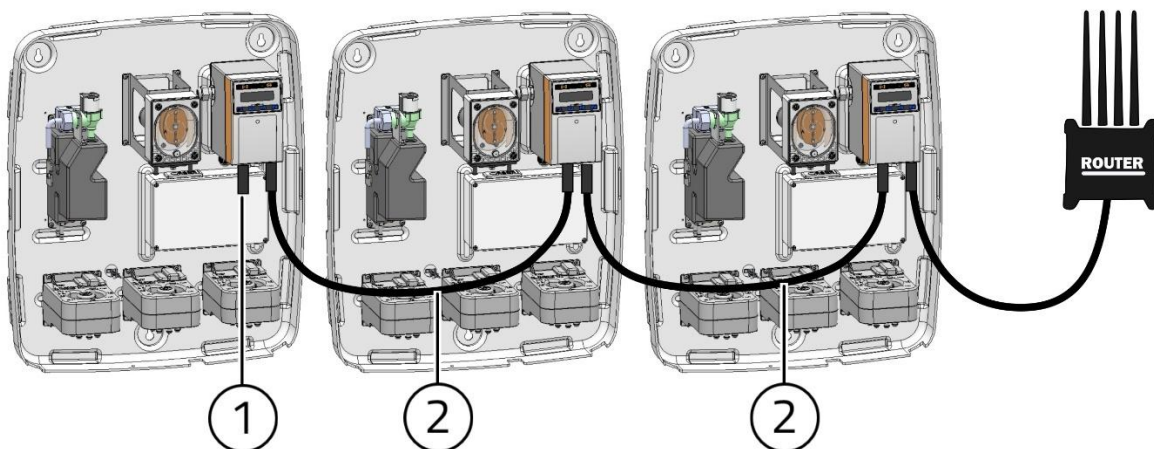

1. Connect the first MPX to the router (see illustration above).
2. Register the MPX in SDDB (see next page).
3. Connect the other MPX with the RS-485 cable (2) (item no. 1005920).
4. In the last MPX, plug the terminating resistor (1) into the left socket on the control unit.
5. Switch the router off and back on again (reboot).

✓ *All MPX are connected and registered in the SDDB.*



Each additional MPX that is connected to the router is automatically registered in the SDDB in the account of the first MPX.

Check the router connection

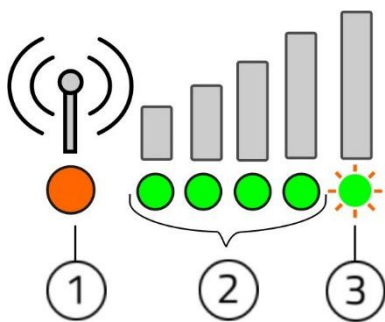
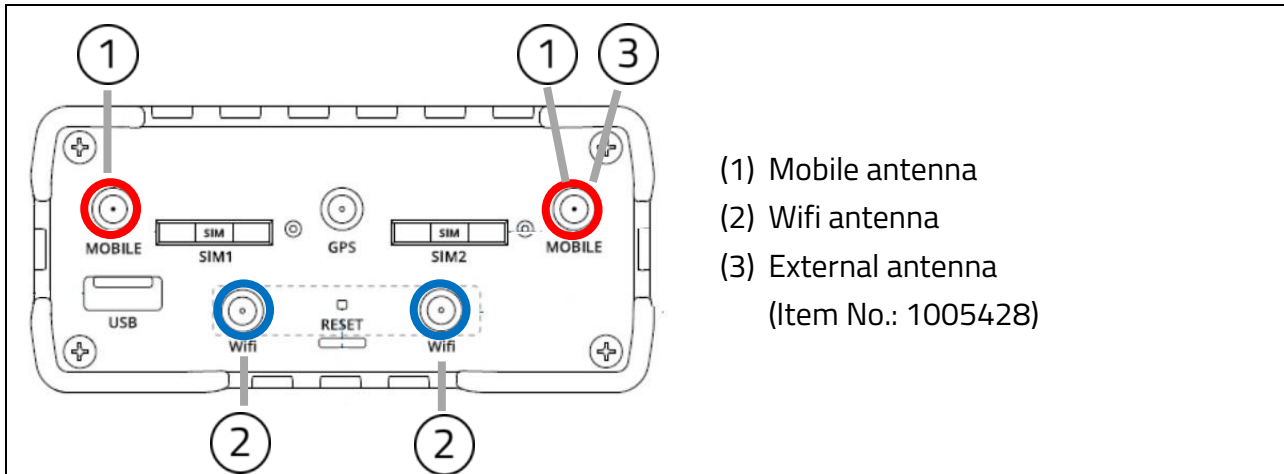

The router LEDs

1) Connection router and Internet

Flashing green and red: no connection

LED flashes (red, orange or green): connected with internet

LED flashes rapidly (red, orange or green): data is being sent

2) Signal reception

At least 3 LEDs must light up.

3) Connection MPX, router and Internet

LED flashes 5x/sec: MPX - router - Internet connected.

LED flashes 1x/sec: Router - Internet connected.

LED flashes every 3 seconds: MPX - router connected.

Registering a device with a QR code in the SDDB web portal

Tutorials SAIER Website (English):

- Register SAIER to the SDDB
- Connect SAIER Router to WIFI



Scan QR-code to see the tutorials

<https://www.saier.eu/en/Accessories%20LTE%20router>

Login data for configuration:

Username: user

Password: User12345678



Information!

The device can also be registered in the database using a QR code before installation.

- The MPX device is registered in the SDDB.*

12 Operating modes

General information on dosing programs

- A dosing program contains one or more dosing steps (e.g. prewash, main wash, bleaching, final rinse).
- A dosing step contains none, one or more product dosings.
- Each start of a dosing program is logged with an event in the event memory.
- Each start of a dosing step is logged with an event in the event memory.
- Each start and each end of a product dosing is logged with an event in the event memory.

12.1 “APD” operating mode



The **APD** (Automatic Program Detection) operating mode is also known as **AFS** (Auto Formula Select). The dosing program is selected automatically when the washing program is selected.

Weighing mode

Washing machines that have a weighing device weigh the load of washing. This weight information is used to adjust the dosing quantity to the laundry load.

The dosing quantity can be reduced in steps of 2.5%, 5% or 10%. The resolution of the weighing mode is specified in the SSC software.

Furthermore, the weighing mode can be activated/deactivated for each washing machine and a minimum dosing quantity can be specified. The factory settings are: Weighing signal resolution 10%, weighing mode activated, minimum dosing quantity 50%.



Transmitting the weighing information (APD1 and APD2)

For a dosing quantity of 100% (full load), the weighing signal has to last 20 seconds.



Pay attention to the correct signal sequence

1. Program detection signal
2. Weighing signal (optional)
3. Start dosing with a delay of at least 20 seconds

Weighing signal	Dosing quantity with 10% resolution	Dosing quantity with 5% resolution	Dosing quantity with 2.5% resolution
> 19.5 s	100%	100%	100%
19.1 s – 19.5 s	100%	100%	97.5%
18.6 s – 19.0 s	100%	95%	95%
18.1 s – 18.5 s	100%	95%	92.5%
17.6 s – 18.0 s	90%	90%	90%
17.1 s – 17.6 s	90%	90%	87.5%
16.6 s – 17.0 s	90%	85%	85%
16.1 s – 16.5 s	90%	85%	82.5%
15.6 s – 16.0 s	80%	80%	80%
15.1 s – 15.5 s	80%	80%	77.5%
14.6 s – 15.0 s	80%	75%	75%
14.1 s – 14.5 s	80%	75%	72.5%
13.6 s – 14.0 s	70%	70%	70%
13.1 s – 13.5 s	70%	70%	67.5%
12.6 s – 13.0 s	70%	65%	65%
12.1 s – 12.5 s	70%	65%	62.5%
11.6 s – 12.0 s	60%	60%	60%
11.1 s – 11.5 s	60%	60%	57.5%
10.6 s – 11.0 s	60%	55%	55%
10.1 s – 10.5 s	60%	55%	52.5%
9.6 s – 10.0 s	50%	50%	50%
9.1 s – 9.5 s	50%	50%	47.5%
8.6 s – 9.0 s	50%	45%	45%
8.1 s – 8.5 s	50%	45%	42.5%
7.6 s – 8.0 s	40%	40%	40%
7.1 s – 7.5 s	40%	40%	37.5%
6.6 s – 7.0 s	40%	35%	35%
6.1 s – 6.5 s	40%	35%	32.5%
5.6 s – 6.0 s	30%	30%	30%
5.1 s – 5.5 s	30%	30%	27.5%
- 5.0 s	30%	25%	25%

APD mode

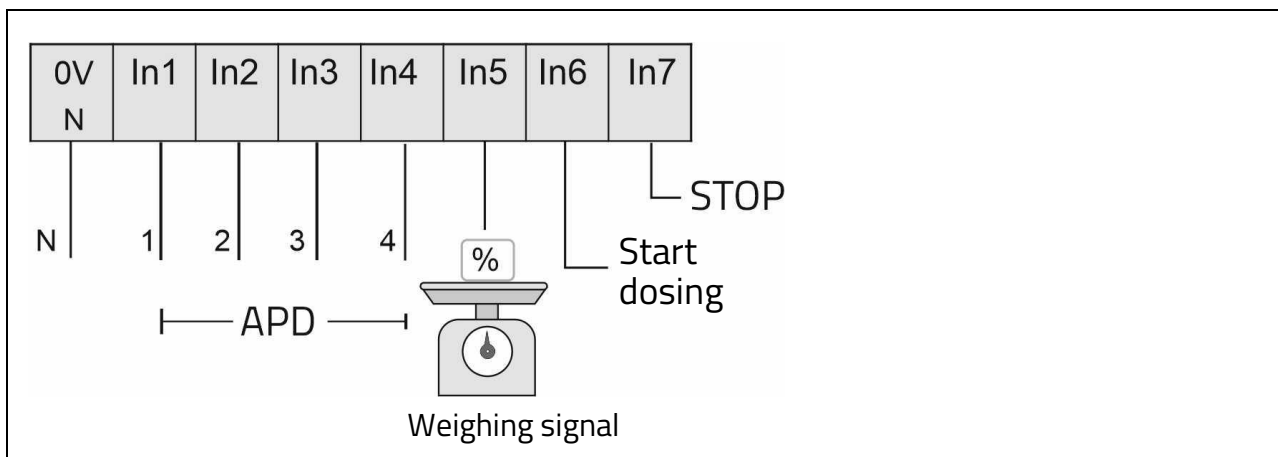

- In1 – In4: Program detection signal pattern (APD).
- In5: Weighing signal (optional).
- In6: Starting dosing step.
- If a signal at In6 starts a new dosing step before a running dosing step is finished, the running dosing step is aborted.
- A signal at In7 stops a running dosing program.

APD mode 2

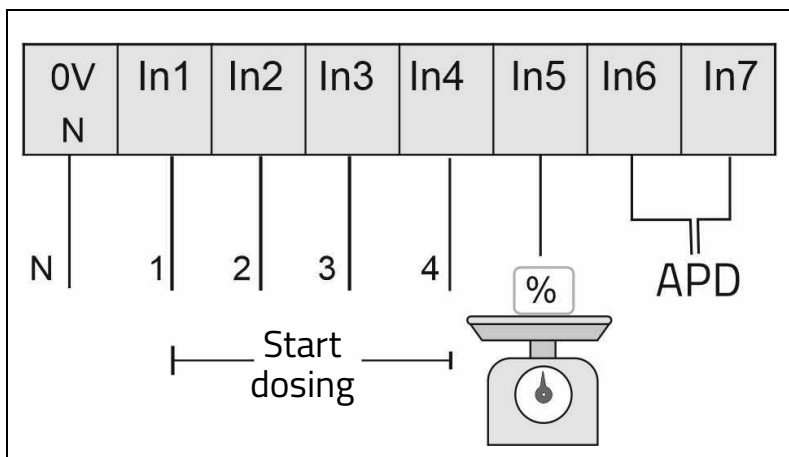

Note: If a dosing system with AFS mode is replaced by an MPX dosing system, APD mode 2 should be used.

It is not necessary to adapt the wiring and programming of the washing machines.

- In1 – In4: Start dosing step (In1 prewash, In2 main wash, In3 disinfection, In4 rinse).
- **IMPORTANT:** Each dosing step requires its own signal, its own line and its own connection (In1 – In4) on the MPX.
- In5: Weighing signal (optional).
- In6 – In7: Program detection signal pattern (APD).
- Dosing steps within the dosing program can be skipped.
- If a signal starts a new dosing step before a running dosing step is finished, the running dosing step is aborted.

12.2 “MPD” operating mode

i An MPX program selector must be installed for **MPD** (Manual Program Detection) operating mode. Dosing programs are selected manually using the MPX program selector and also started manually depending on the MPD mode.

MPX program selector

Electrical installation



The following wires need to be run from the washing machine to the In terminals on the MPX:

MPD mode 1

<table border="1"> <tr> <td>0V</td> <td>In1</td> <td>In2</td> <td>In3</td> <td>In4</td> <td>In5</td> <td>In6</td> <td>In7</td> </tr> <tr> <td>N</td> <td></td> <td></td> <td></td> <td></td> <td></td> <td></td> <td></td> </tr> </table>	0V	In1	In2	In3	In4	In5	In6	In7	N								<p>In6 = Drain valve In7 = Door contact</p>
0V	In1	In2	In3	In4	In5	In6	In7										
N																	
<ul style="list-style-type: none"> - Closing the door starts the selected dosing program. - A signal at terminal In1 – In5 starts the first dosing step. - Before the next dosing step can be carried out, the drain valve (signal at In6) must open and then close again. - A further signal at In1 – In5 starts the next dosing step. - The door must remain closed until the end of the washing program. - No dosing steps can be skipped within the dosing program. - If a signal starts a new dosing step before a running dosing step is finished, the running dosing step is aborted. 																	

MPD mode 2

0V	In1	In2	In3	In4	In5	In6	In7
N							
N	R1	R2	R3	R4	R5	R6	STOP

- The selected dosing program is started at the program selector.
- A signal at In1 – In6 starts the first dosing step of the dosing program.
- Further signals at In1 – In6 start the next dosing steps.
- Dosing steps within the dosing program can be skipped.
- If a signal starts a new dosing step before a running dosing step is finished, the running dosing step is aborted.
- A signal at In7 stops a running dosing program.

MPD mode 3

0V	In1	In2	In3	In4	In5	In6	In7
N							
N	R1	R2	R3	R4	R5	R6	



In7 = Door contact

- Closing the door starts the selected dosing program.
- A signal at In1 – In6 starts the first dosing step of the dosing program.
- Further signals at control inputs In1 – In6 start the next dosing steps.
- Dosing steps within the dosing program can be skipped.
- If a signal starts a new dosing step before a running dosing step is finished, the running dosing step is aborted.
- Opening the door ends the dosing program.

MPD mode 4

0V	In1	In2	In3	In4	In5	In6	In7
N							

N	R1	R2	R3	R4	R5
---	----	----	----	----	----

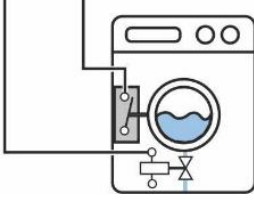

In6 = Drain valve
In7 = Door contact

- Closing the door starts the selected dosing program.
- A signal at In1 – In5 starts the first dosing step of the dosing program.
- Before the next dosing step can be started, the signal for the drain valve at control input In6 has to be switched on once and then switched off again.
- Further signals at In1 – In5 start the next dosing steps.
- Dosing steps within the dosing program can be skipped.
- Opening the door ends the dosing program.

MPD mode 5

0V	In1	In2	In3	In4	In5	In6	In7
N							

N	R1	R2	R3	R4	R5
---	----	----	----	----	----



In6 = Drain valve

- The selected dosing program is started at the program selector.
- A signal at In1 – In5 starts the first dosing step of the dosing program.
- Before the next dosing step can be started, the signal for the drain valve at control input In6 has to be switched on once and then switched off again.
- Further signals at In1 – In5 start the next dosing steps.
- Dosing steps within the dosing program can be skipped.
- A signal at In7 stops a running dosing program.

MPD mode 6

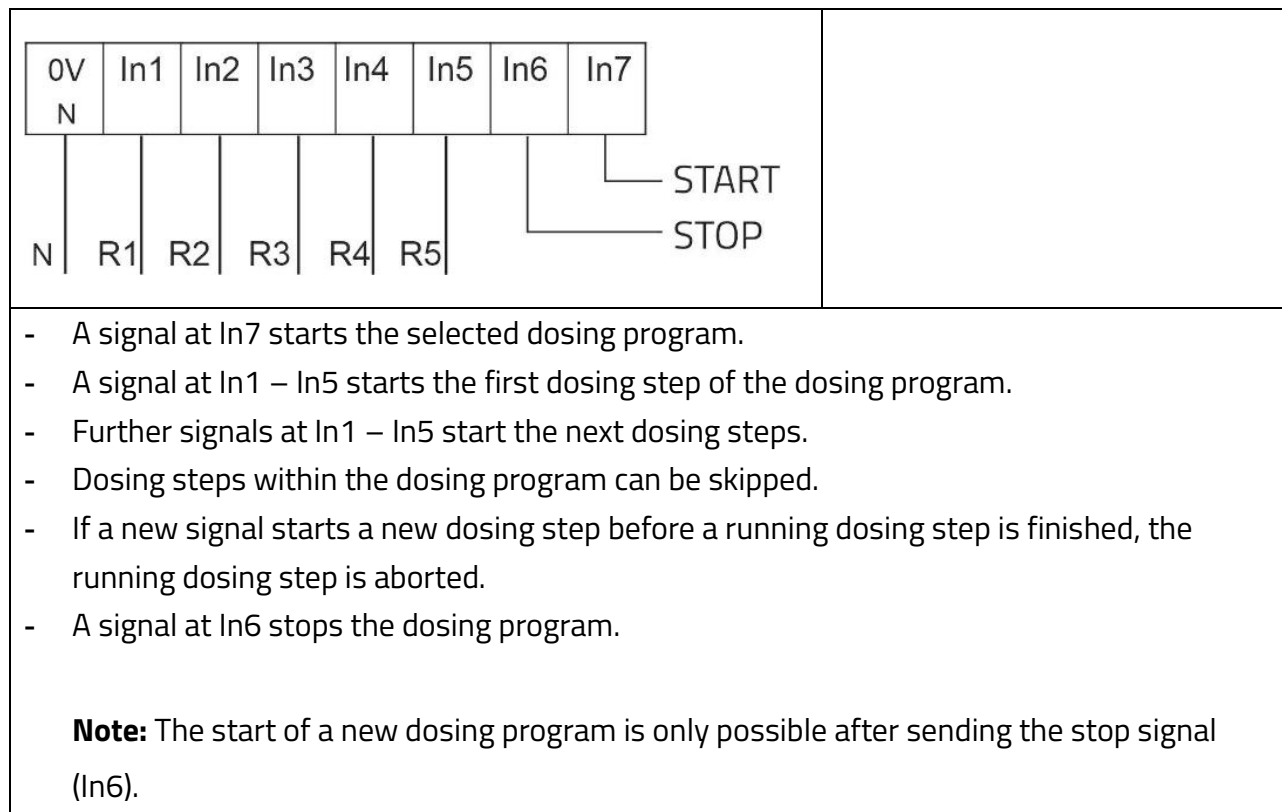

12.3 “Direct” operating mode

Washing machines with dosing programs control the type and quantity of washing chemicals. This is done by providing a separate control signal for each washing chemical. The following types of control signals are possible:

- **“1:1” control signal**
 The control outputs on the washing machine are connected directly 1:1 to the In terminals on the MPX. One line is required per washing chemical.
- **“Direct sum” control signal** (programming required)
 Two control outputs are activated simultaneously to generate a new signal. The sum of the signal numbers gives the new signal number (In1 and In3 produce signal 4 and dose washing chemical 4).
- **“Direct binary” control signal** (programming required)
 The binary coded signal at the In terminals controls the product position.

13 Menu

















13.1 Display

The display shows the following information:

- Status display (e.g. flushing)
- Error messages (e.g. tube rupture)
- Input displays (e.g. input dosing)

Symbols on the display

Symbols are shown on the display. These symbols explain the displayed values.

Symbol	Description	Meaning
  	Fresh water closed Water reservoir empty	There is no fresh water in the water reservoir. The water supply is closed.
   	Fresh water open Water reservoir empty	The water reservoir is being filled.
   	Fresh water open Level 1 reached	The water reservoir is being filled. The water reservoir is filled up to level 1.
  	Fresh water closed Level 2 reached	The water reservoir is full.
 OX	Washing chemical OX	The washing chemical with the indicated number is being dosed.
	Flushing	The machine is being flushed with fresh water.

Display layout

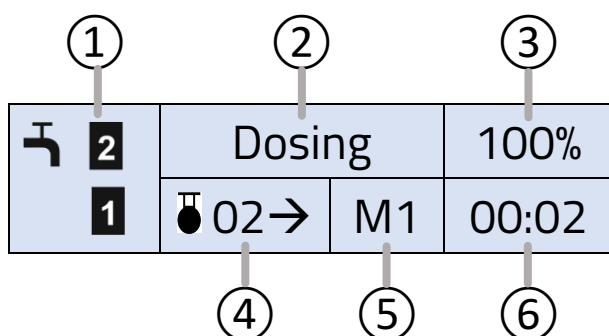

- (1) Water reservoir status
- (2) Current activity
- (3) Pump power
- (4) Washing chemical
- (5) Washing machine
- (6) Time of the activity

Arrows

Top arrow: Press the button to open the menu.

Bottom arrow: Press the button to confirm the value.

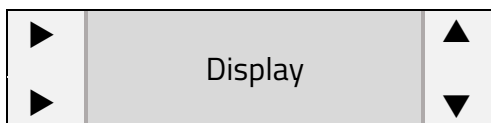

- Select menus
- Change values

Button functions

Button	Navigate through the menu	Enter values
<input type="checkbox"/>	Exit the menu	Back to the previous value
<input type="checkbox"/>	Back to the previous menu	Increase value by 1
<input type="checkbox"/>	To next menu	Decrease value by 1
<input checked="" type="checkbox"/>	Open menu Exit menu after entering value	Confirm value

Navigate and change values

Select and open menu

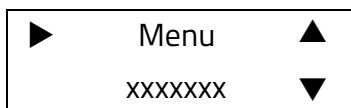

Select the menu using the and buttons.
Press the button to open the menu.

Change values

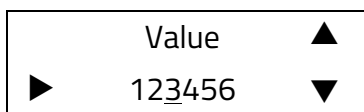

Use the and buttons to increase/decrease the value.
Press the button to confirm the value.

Note: The underlined value can be changed.

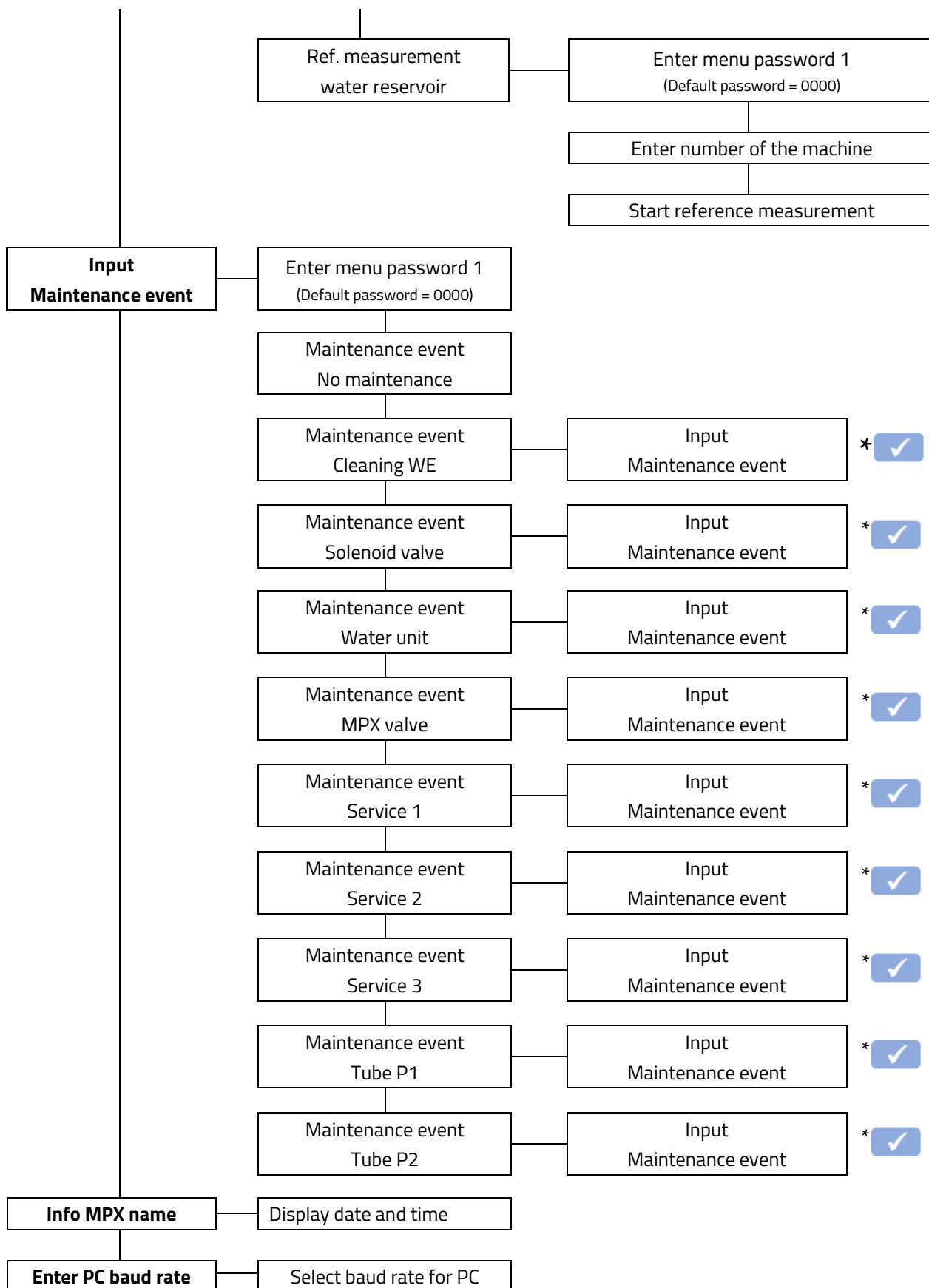

* Press the ENTER key to confirm the servicing/maintenance work, which then appears in the Saier Device Database (SDDB).

Flush line

If a dosing procedure is cancelled, there is washing chemical in the line. For this reason, the line has to be flushed manually.



If the line is not flushed, the system remains in “MPX system deactivated” mode and the dosing system cannot be started.

Drain water reservoir

During the “Drain water reservoir” operation, the pump pumps all the water in the water reservoir into the washing machine. This action is required e.g. before changing the tube.

Initial flush

After installing the dosing system, the “Initial flush” must be carried out as the first functional test. With the “Initial flush”, the MPX multiplexer(s) move(s) to all flushing positions and perform(s) an intermediate flush.

Manual multi-dosing

This function enables dosing operations for one or more washing chemicals.

“Manual multi-dosing” can be used during initial startup to fill the lines from the containers to the MPX multiplexer(s).



Aggressive chemicals

- ▶ Make sure that the washing chemicals are diluted and completely pumped into the washing machine.
- ▶ Make sure that unwanted chemical reactions do not occur when dosing multiple washing chemicals in one operation.

Password protection

If the wrong password is entered three times, the menu is locked for 10 minutes. During this time, the unit must not be switched off and no button must be pressed.

After the lockout period, three more attempts are possible.

Menu password 1 can only be changed using the SSC software and the data transfer adapter. “Menu password 2” (the main password) is required for this. (Default menu password 2 = 0000).

Water reservoir reference measurement

The MPX monitors the tube ageing process and adjusts the parameters accordingly (automatic compensation for tube ageing). This compensation ensures that dosing remains consistent.

In order for the compensation to be carried out correctly, a reference measurement for the tube must be carried out during initial setup.

<input checked="" type="checkbox"/> Automatic compensation of pump tube aging
Reference value tube aging <input type="text" value="19.3s"/>
Current compensation value <input type="text" value="0%"/>

The reference measurement takes about several minutes. The reference value for the tube ageing is entered in the SSC software.

The current compensation value is determined during operation and is displayed in the SSC software.

MPX DUO: With this device, a reference measurement must be carried out for each pump.

Enter maintenance event

This menu item is used to document maintenance work on the system. After carrying out a maintenance task, the service technician confirms that the work has been carried out. This confirmation is listed and displayed in the SDDB.

With the confirmation of a maintenance task, the corresponding counter is set to zero. This allows maintenance logs to be produced for the operator, and enables useful scheduling of maintenance work.

The following maintenance tasks can be documented in the MPX menu:

- Replace pump tube
- Replace solenoid valve
- Replace water unit
- Replace MPX valve 1
- Replace MPX valve 2
- Replace MPX valve 3
- Replace dosing pump
- Clean water unit
- General service
(self-defined maintenance steps)

MPX DUO:

Service 1, 2 and 3 can be defined by the user.

Purging air from a dosing line



Trained personnel only!

Purging air may only be carried out by a trained person.

Before purging air, all dosing lines must be connected on the washing machine and MPX dosing system. After purging, the line must be flushed with water.

Requirements

- No dosing program must be active on the selected washing machine.
- The selected washing machine must be empty (no laundry in the washing drum).
- The purging process must last no more than 60 seconds, after which the line to the selected washing machine is automatically flushed.
- The dosing system must be activated.

If a dosing is requested by another washing machine during the purging process, this request will be carried out after the current purging process.

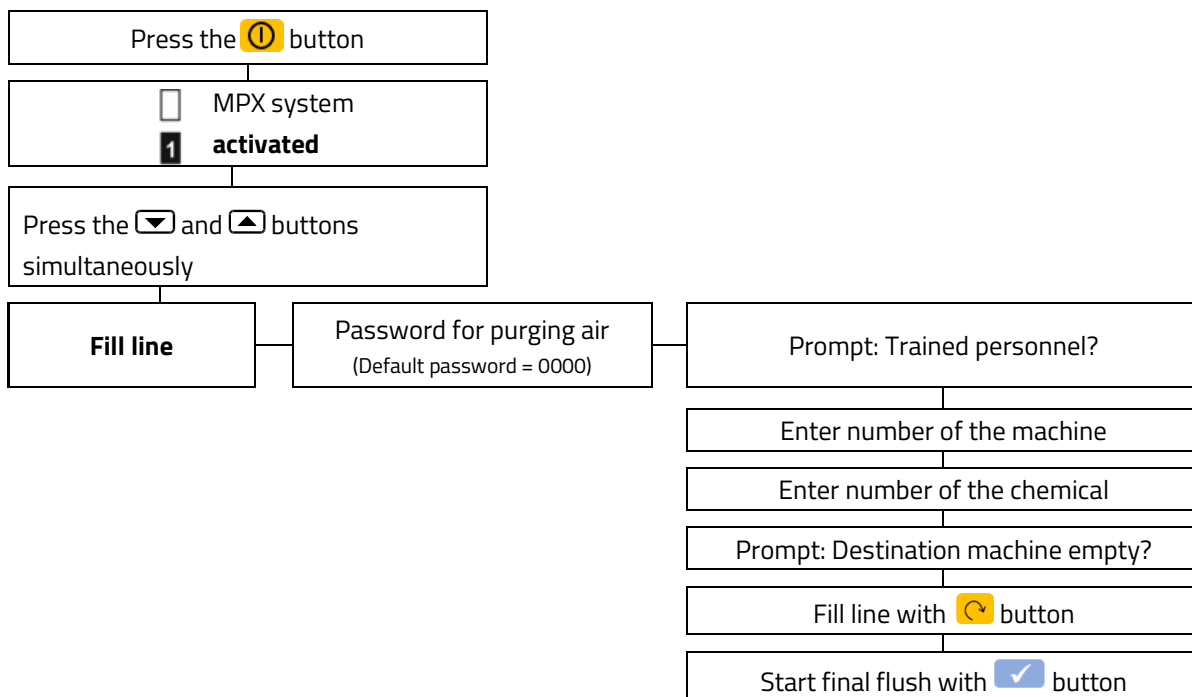

Password duration

The password must be re-entered after one hour.

14 Startup

Installation	
1.	Mount the MPX unit.
2.	Install I/O modules.
3.	Install the program selector.
4.	Install the flashing warning light.
5.	Connect potable water supply to MPX.
6.	Connect washing machines to MPX with hoses.
7.	Connect suction lances to MPX with hoses.

Electrical installation		
1.	MPX	Connect supply voltage.
2.		Connect external warning signal to SD bus (optional).
3.		Connect suction lances.
4.		Connect control outputs from washing machine 1.
5.		Remove T-jumper (terminating jumper).
6.	I/O module 1	Connect washing machine 2 to SD bus.
7.		Connect control outputs from washing machine 2.
8.		Connect address jumper to JPG 1 (see instructions for MPX I/O module).
9.	I/O module	Connect washing machine 3 to SD bus.
10.		Connect control outputs from washing machine 3.
11.		Connect address jumper to JPG 2 (see instructions for MPX I/O module).
12.	Connect the additional I/O modules as described above.	
13.	For MPD mode, connect program selector to SD bus (see program selector instructions).	
14.	Fit T-jumper at end of the bus (last I/O module).	

MPX configuration	
1.	Install SSC software on the PC.
2.	Use the SSC software to create the MPX program (see SSC software instructions).
3.	Connect the PC to the MPX via the data transfer adapter.
4.	Transfer program data to the MPX.

Remote control configuration

1.	Create account in the SDDB web platform for the service technician (administrator).
2.	Give the login data (name and password) to the service technician.
	Switch on the router and wait a few minutes.
3.	Plug in the MPX's mains power plug.
4.	 Press the "on/off" button (deactivate MPX system).
5.	Connect PC and router.
6.	Start SSC software.
7.	Enter the service technician's login data (see SSC software instructions).

Test run

1.	Open the water supply tap.
2.	Check water connection at solenoid valve for leaks.
3.	Carry out "Initial flush".
4.	Carry out "Water reservoir reference measurement".
5.	Carry out "Manual multi-dosing" (purge air from dosing tubes).
6.	Calibration.
7.	 Press the "on/off" button (activate MPX system).
8.	Run a wash program on each washing machine.
9.	In the SSC software, view the event list and check the dosing events (Events area: "► Read events").

The dosing system is ready for operation.



IMPORTANT INFORMATION FOR MPX DUO

The following functions must be carried out when setting up the MPX DUO for machine 1 and machine 2:

- Flush line
- Initial flush
- Drain water reservoir
- Water reservoir reference measurement

14.1 Calibration



Chemical burn hazard from chemicals

Calibration of the dosing pump may be carried out only by instructed personnel who have been informed of all hazards and who have received documented training for this activity.



Wear eye protection.



Wear protective clothing.



Wear protective gloves.



Protect the surroundings.

You will need:

- Chemical tube (Ø 8 mm) for connection to the MPX de-multiplexer or pump
- Collecting container
- Measurement beaker
- Scale if necessary
- Covering material to protect the surrounding area
- Calibration report form and ballpoint pen

Method

1. Connect the chemical tube to output 7 on the MPX de-multiplexer.
MPX Smart or MPX Solo: Connect the chemical tube to the output on the dosing pump.
2. Place the measurement beaker and collecting container in a stable position on the covering material.
3. Insert the chemical hose into the collecting container and fix in place.
4. Deactivate the MPX system.
5. Select "Calibrate" in the menu (see menu on page 39).
6. Enter the number 7 for the destination machine.

Destination machine number: 7

7. Enter the number of the chemical.



Select product Chem.: xx

8. Enter dosing rate and dosing time for the calibration.

Pump mm:ss 100% 00:15

9. Confirm that you are trained for this activity.

Trained and ready? Yes

- ▶ The MPX system performs a water check and pre-flushes the line.
10. Press the  button until the line to the collecting container is filled with chemical.
 11. Insert the chemical hose into the measurement beaker and fix in place. Avoid contaminating the surrounding area with chemical from the hose.
 12. Press the  button.
 - ▶ The pump runs for the specified time.
 13. Put the hose back into the collecting container and fix in place. Avoid contaminating the surrounding area with chemical from the hose.
 14. Read off the quantity in the measurement beaker and write it down on the calibration report form.
 15. If necessary, determine the weight and also write it down on the calibration report.
 16. Carry out the measurement for the other flow rates (75%, 50%, 25%). To do this, repeat steps 8 – 15 in each case.

New measurement? Yes

 17. For the calibration values of another washing chemical, the answer No must be entered in response to the question “New measurement?”

New measurement? No

 18. Carry out the required step “Flush line”; the contents of the line are flushed into the collecting container. **Caution: Splash hazard!**
 19. Empty the measurement beaker and collecting container properly and clean thoroughly.
 20. Determine the calibration values of the other washing chemicals as described in steps 5 – 19.
 21. Enter all calibration values for the washing chemicals in the product administration area in the SSC software, and transfer them to the MPX dosing system.

Note: For the individual chemicals, calibration values can only be entered for the flow rates that are possible based on the configuration.

Product name	<input type="text" value="Product x"/>			
Product number	<input type="text" value="x"/>	<input type="button" value="▲"/> <input type="button" value="▼"/>		
Maximum flow rate	<input type="text" value="... %"/>	<input type="button" value="▼"/>		
Density	<input type="text" value="... g/ml"/>	<input type="button" value="▲"/> <input type="button" value="▼"/>		
Calibration value 100%	<input type="text" value="... ml/min"/>	<input type="button" value="▲"/> <input type="button" value="▼"/>	<input type="text" value="... g/min"/>	<input type="button" value="▲"/> <input type="button" value="▼"/>
Calibration value 75%	<input type="text" value="... ml/min"/>	<input type="button" value="▲"/> <input type="button" value="▼"/>	<input type="text" value="... g/min"/>	<input type="button" value="▲"/> <input type="button" value="▼"/>
Calibration value 50%	<input type="text" value="... ml/min"/>	<input type="button" value="▲"/> <input type="button" value="▼"/>	<input type="text" value="... g/min"/>	<input type="button" value="▲"/> <input type="button" value="▼"/>
Calibration value 25%	<input type="text" value="... ml/min"/>	<input type="button" value="▲"/> <input type="button" value="▼"/>	<input type="text" value="... g/min"/>	<input type="button" value="▲"/> <input type="button" value="▼"/>

✓ *The dosing system is calibrated.*

15 Maintenance

The peristaltic pump is a low-maintenance pump. The pump tube is subject to chemical and mechanical stress and wear.

If the pump does not reach the desired pump pressure even after replacing the tube, the rotor has to be replaced.



CAUTION!

Danger of death, electricity

- ▶ Before opening the device housing, disconnect the power supply to the device and make sure it cannot be switched back on.



CAUTION!

Device is under pressure

- ▶ Before disconnecting the tube, first depressurise the device to prevent chemicals from spraying.
- ▶ Wear personal protective equipment in compliance with accident prevention regulations.

15.1 Replacing the tube kit and the rotor



Escape of liquid!

Carry out the "Drain water reservoir" command before replacing the tube!

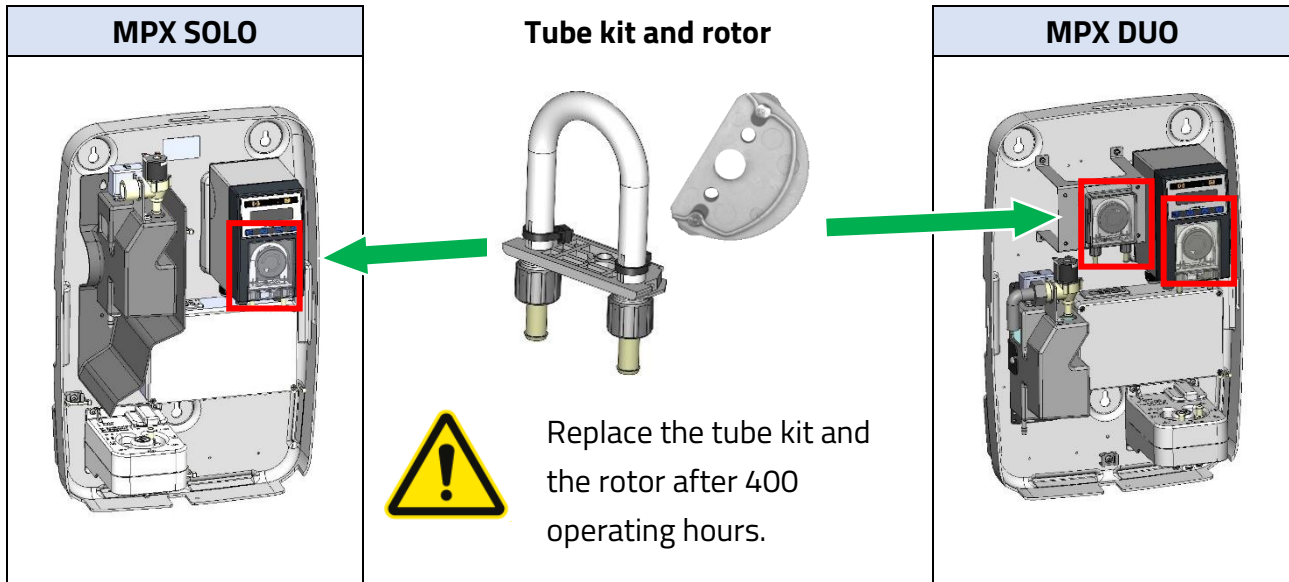

Crush hazard

- Before replacing the tube, switch off the device and make sure it cannot be switched back on.
- Before switching on the pump, ensure that all covers are properly fitted.



Chemical burn hazard

Corrosive product residues can cause severe eye and skin injuries!



Wear eye protection and protective gloves.



Never grease the tube

Greased tube will fall out of the guide.

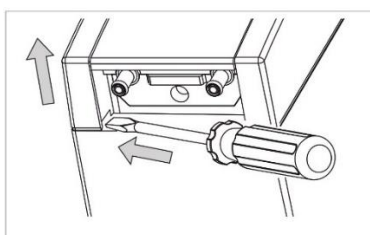

- ▶ Gently insert a screwdriver into the two openings in the shroud cover.
- ▶ Lift the shroud cover.

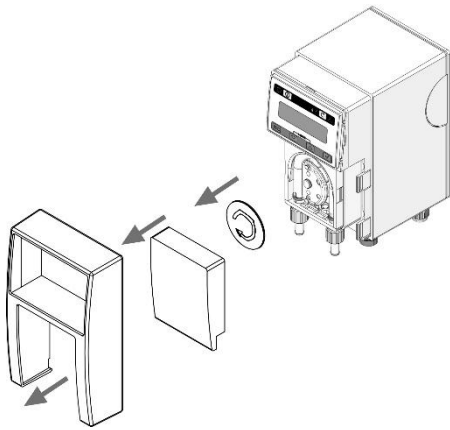

- ▶ Remove the shroud cover.
- ▶ Remove the pump housing cover.
- ▶ Remove the rotor cover.

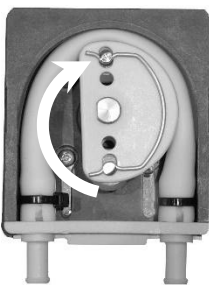

- ▶ Use long-nose pliers or a rotor key to rotate the rotor clockwise into the "D" position.

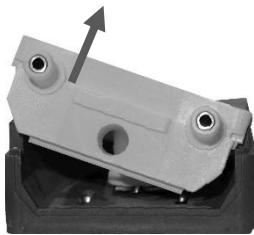

- ▶ Pull the tube holder down out of the fitting.

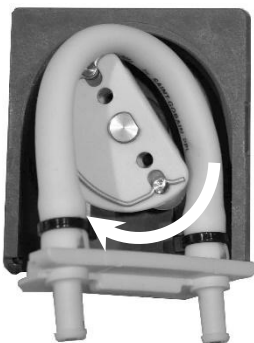

- ▶ Continue turning the rotor clockwise until the pump tube is free.
- ▶ Remove the tube kit.

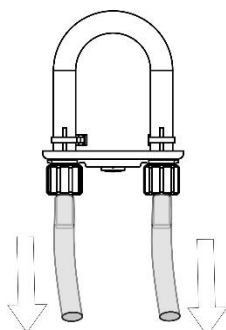

Caution, splash hazard

- ▶ Cover tube holder with a cloth.
- ▶ Remove tube clips
- ▶ Pull the pump tube away from the connection.
- ▶ Clean pump housing.

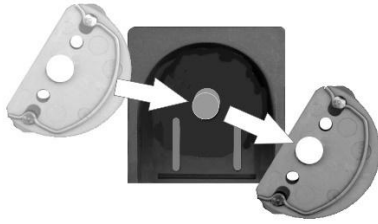

- ▶ Replace the rotor.



- ▶ Rotate the rotor into angled "D" position.

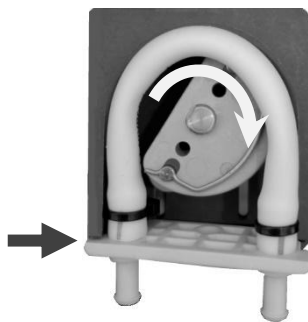

- ▶ Place new tube in position to the left of the rotor.
- ▶ Slide the tube holder into the guide on the left (➡).
- ▶ Continue turning the rotor clockwise.
- ▶ While turning the rotor, press the pump tube into the guide.

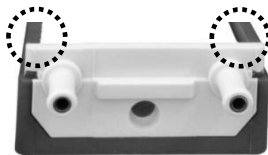

- ▶ Slide the tube holder fully into both guides.
- ▶ Check that the tube holder sits flush.

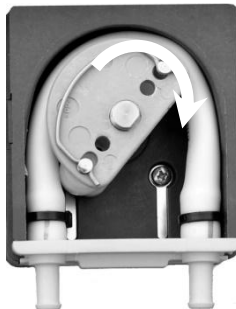

- ▶ Rotate the rotor several times to align the pump tube.
- ▶ Press the sealing plug into the opening in the tube holder so that the tube rupture monitoring feature works.

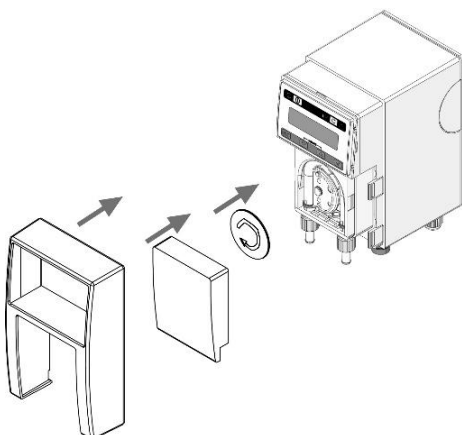

- ▶ Fit rotor cover.
- ▶ Fit pump housing cover.
- ▶ Fit shroud cover.
- ☑ *The tube kit has been replaced.*

15.2 Replacing the tube



Escape of liquid!

Carry out the "Drain water reservoir" command before replacing the tube!

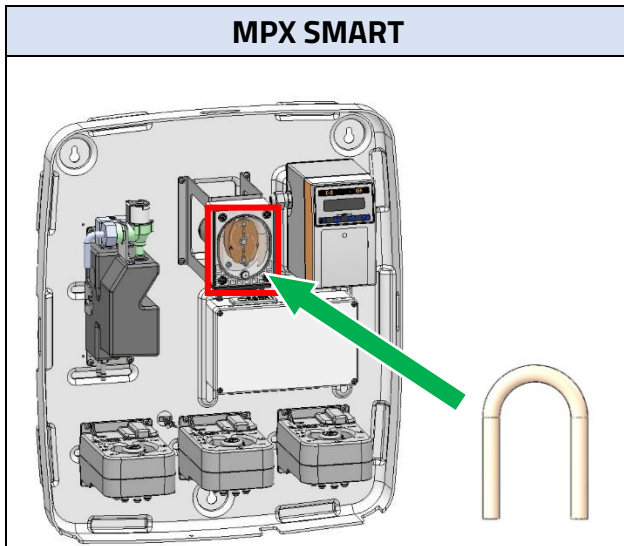

Replace the tube after 400 operating hours.



Crush hazard

- Before replacing the tube, switch off the device and make sure it cannot be switched back on.
- Before switching on the pump, ensure that all covers are properly fitted.



Chemical burn hazard

Corrosive product residues can cause severe eye and skin injuries!



Wear eye protection and protective gloves.



Never grease the tube

Greased tube will fall out of the guide.

- ▶ Drain the water reservoir.
- ▶ Remove the housing cover (1).
- ▶ Remove the retaining ring (2).
- ▶ Rotate and pull the rotor (3) to remove it from the pump housing.

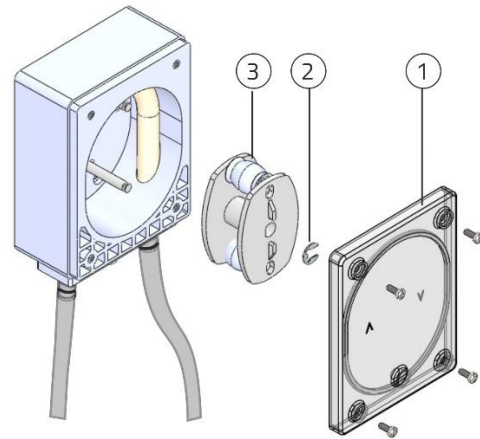

- ▶ Remove screw (1) from the tube holder (2).
- ▶ Pull down on the tube holder with the tube until the tube is hanging on the shaft.

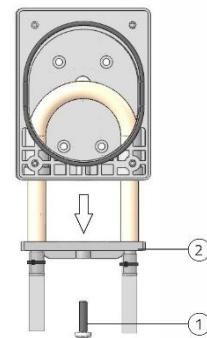

- ▶ Pull the tube ends to detach them from the tube holder (1).
- ▶ Remove tube from the pump housing.

☑ *The old tube is removed.*

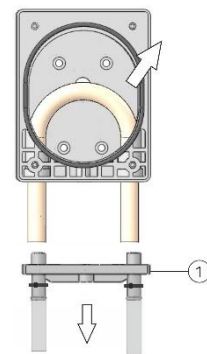

- ▶ Clean the inside of the pump housing.

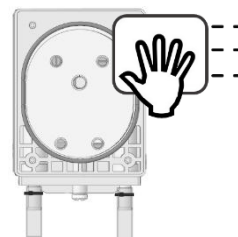

- ▶ Insert a new tube into the pump housing.
- ▶ Attach the tube to the tube holder.
- ▶ Secure the tube holder using the screw.

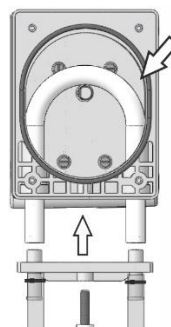

- ▶ Bend the tube downwards.
- ▶ Fit the rotor onto the shaft.

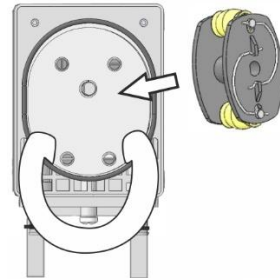

- ▶ Push the tube into place to the left of the rotor.
- ▶ Place the rotor key onto the rotor.

i The rotor key is not supplied with the unit.
It is an accessory (art. no. 1003270).

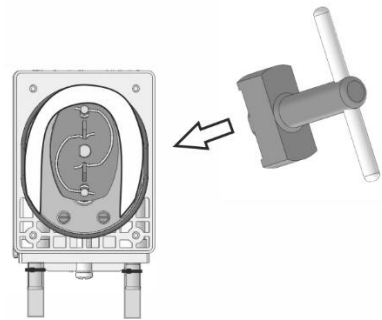

- ▶ Turn the rotor clockwise and push the tube into place to the right of the rotor.
- ▶ Turn the rotor until the tube is correctly positioned in the guide path.

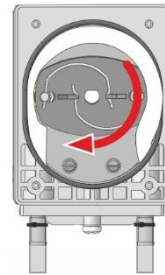

- ▶ Fit the retaining ring.
 - ▶ Refit the housing cover with the screws.
- The tube is replaced.*

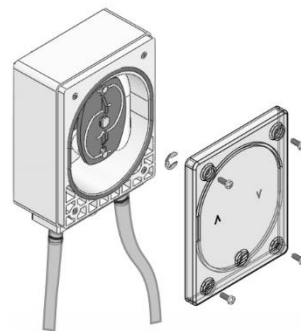

15.3 Check and clean the level rods

Visually inspect the level rods once a year. Depending on the water hardness, the level rods in the water tank may become calcified. The level rods can be cleaned with a commercially available descaler.



WARNING – ELECTRICAL VOLTAGE

The system must be disconnected from the power supply before working on the water unit. Secure the system against being switched back on.



CAUTION – Corrosive descaler





Wear protective gloves and safety goggles when handling descaler. Avoid contact with skin and eyes. The manufacturer's instructions must be followed.

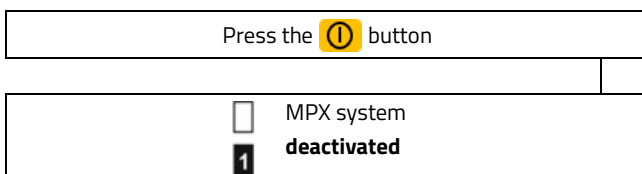

15.4 Descaling the level rods

- ▶ Remove the MPX cover.
- ▶ Deactivate the system.



- ▶ Press the  and  buttons simultaneously to open the menu.
 - ▶ „Start operations manually“ select and confirm with the button .
 - ▶ „Drain water reservoir“ select and confirm with the button .
 - ▶ Enter number of the machine and confirm with the button .
 - ▶ Select „Start draining water reservoir“.
- Water tank is being emptied.*

Fill the water tank with descaler



Important information!

When filling the water tank with descaler, make sure that no liquid runs out of the overflow window.

- ▶ Fill the water tank through the side opening with descaler until the level rods are completely covered.
- ▶ Leave the descaler to work for several hours or overnight.









Important information!

Shut down the system until the level rods have been descaled.

- ☑ *The water tank is filled with descaling agent.*

Emptying the descaler

- ▶ Press the  and  buttons simultaneously to open the menu.
- ▶ „Start operations manually“ select and confirm with the button .
- ▶ „Flush line“ select and confirm with the button .
- ▶ Enter number of the machine and confirm with the button .
- ▶ „Start flushing line“ select and confirm with the button .
- ▶ Descaler emptied from the water tank.



Important information!

To ensure that the water tank is completely emptied of descaler, these steps **must be performed twice**.

- ▶ Activate the system.
 - ✓ *Descaling of the level rods is complete.*

15.5 Confirm and document maintenance work



Confirm maintenance work!

Completed maintenance work must be confirmed in the [MPX menu](#).

15.6 Confirm and document maintenance tasks



Confirm maintenance task

After carrying out maintenance tasks, confirm them in the MPX menu.

The following maintenance tasks can be documented in the MPX menu (see page 39):

- Replace pump tube
- Replace solenoid valve
- Replace water unit
- Replace MPX valve 1
- Replace MPX valve 2
- Replace MPX valve 3
- Replace dosing pump
- Clean water unit
- General service (self-defined maintenance steps)

16 Event log

The dosing system has an internal memory (data logger). This memory logs errors, faults and work steps of the dosing system. A maximum of 1,400 events per day and a total of 41,000 events can be stored.

16.1 Types of events

Events with time stamp

The following events are stored together with the time they occurred:

- Dosing system supply voltage on/off
- Dosing system activated/deactivated
- Faults/warnings on/off
- Acknowledgement of faults/warnings
- Start time / end time of dosing programs
- Start time / end time of dosing steps
- Start time / end time of product dosings

Operations with time duration per day:

The time duration is stored for the following operations each day:

- Total daily dosing time of each product
- Daily dosing time of each product dosed at 100% flow rate
- Total daily duration of water flushing
- Daily duration of water flushing that was carried out at 100% flow rate



Reading the event log

The event log can only be read out using the SSC software.

Note: If the MPX is registered on the MPX web platform (SDDB), the event data is sent to the MPX web platform with a slight time delay. The data can be viewed and evaluated there.

17 Faults

Error messages on the MPX display:

Error message	Cause	Remedy
Deactivated	Standby mode.	Press the  button. Press "Operating mode".
Empty signal! Container	<ul style="list-style-type: none"> • Container empty. • No suction lance connected. • Suction lance faulty. • Wrong configuration. 	<ul style="list-style-type: none"> • Provide new container. • Check suction lance is connected and seated properly. • Invert suction lances
Error water supply check	No water flowing into the water tank.	<ul style="list-style-type: none"> • Check water supply. • Check water level in tank. • Check solenoid valve. • Check signal at solenoid valve.
Level control water drain	<p>No or too little water is drawn from the water reservoir during flushing.</p> <ul style="list-style-type: none"> • Water reservoir clogged. • Multiplexer faulty. • Dosing pump not working properly. • Monitoring time for draining water from the reservoir is set too short. • Tube to the machine blocked or kinked. • Inlet connection on the machine is not open sufficiently or not open at all. 	<ul style="list-style-type: none"> • Check water reservoir. • Check multiplexer. • Check that dosing pump is working properly. • Check "Monitoring time for water drain" in the SSC software.
Level control water overflow	<p>Water reservoir is overflowing.</p> <ul style="list-style-type: none"> • Solenoid valve faulty. • Pressure fluctuations in the water supply. • Dirty or calcified level rods 	<ul style="list-style-type: none"> • Check solenoid valve and replace if necessary. • Even out pressure fluctuations. • Fill the water unit with descaler. Then empty the water tank.
Error timeout	MPX multiplexer does not reach the dosing position within the allotted time.	<ul style="list-style-type: none"> • Replace MPX multiplexer.
Error module	MPX multiplexer is not responding to control signals from the main control unit.	<ul style="list-style-type: none"> • Replace MPX multiplexer.
Error blockage	<p>MPX multiplexer is jammed.</p> <ul style="list-style-type: none"> • Dried-out chemical residues in the MPX multiplexer. • Film of liquid has evaporated. 	Use a pin spanner to free the multiplexer.

Error message	Cause	Remedy
I/O module error	No connection to an I/O module. <ul style="list-style-type: none"> • Not connected correctly. • Jumper in wrong position or not fitted. • Wrong configuration. 	<ul style="list-style-type: none"> • Check electrical connection. • Check jumpers (ensure correct bus termination). • Check configuration in the SSC software.
Tube rupture! Dosing pump!	Pump tube leakage.	<ul style="list-style-type: none"> • Replace tube. • Clean pump housing. • Acknowledge error.
Signal error Control signal	Wrong signal from the washing machine for a product position on the multiplexer.	<ul style="list-style-type: none"> • Correct the washing machine's dosing program. • Check configuration in the SSC software.
Power failure while dosing	Power failure while dosing in progress.	Restart dosing operation.
Device error Device: MPX	<ul style="list-style-type: none"> • Incorrect connection of an external bus device (bus communication fault). • Multiplexer faulty. 	<ul style="list-style-type: none"> • Disconnect the plug connectors of the external SD bus. <p><u>Alarm stops:</u> Rectify the incorrect connection of the bus device.</p> <p><u>Alarm continues:</u> Disconnect the plug connectors of the internal SD bus. Determine which multiplexer is faulty and replace it.</p>
Device error Device: PERI	Incorrect connection of an external bus device (bus communication fault).	<ul style="list-style-type: none"> • Disconnect the plug connectors of the external SD bus. <p>Determine which bus device is connected incorrectly or faulty. Replace faulty bus device.</p>
Panel error	No connection to program selector. <ul style="list-style-type: none"> • Not connected correctly. • Wrong machine number. • Wrong configuration. 	<ul style="list-style-type: none"> • Check electrical connection. • Enter correct machine number. • Check configuration in the SSC software.
** Wrong ** * Code number! *	Wrong password entered.	Enter correct password.

18 Replacement parts and support

Device type and serial number required

When ordering replacement parts, always specify the exact device type and the serial number. This information is provided on the device's nameplate.

For warranty reasons, use only original replacement parts!

MPX SMART replacement parts

Mat. no.	Description
43145	MPX SMART pump tube TS4 (1 pc.)
1004829	MPX SMART pump tube TS4 (10 pcs.)
1004830	MPX SMART pump tube TS4 (100 pcs.)
1003350	Retaining ring for rotor (10 pcs.)
1005573	MPX SMART pump
1003499	MPX solenoid valve
1005575	MPX SMART rotor black
1003498	MPX water tank with splash guard
1002402	MPX multiplexer 7-1
1004878	MPX SMART multiplexer 7-7
1004879	MPX SMART de-multiplexer
1005579	MPX connection box board
1005582	MPX SMART control unit
1005583	MPX SMART power supply board
1005670	MPX SMART cover
1005675	MPX splash guard
1005277	Multiplexer-pump tube

MPX SOLO replacement parts

Mat. no.	Description
1006402	MPX SOLO pump kit (pump tube + rotor)
1003499	MPX solenoid valve
1003498	MPX water tank with splash guard
1002402	MPX multiplexer 7-1
1005579	MPX connection box board
1005580	MPX SOLO control unit with pump
1005673	MPX SOLO cover
1005675	MPX splash guard
1005277	MPX multiplexer-pump tube

19 Dismounting and disposal



Danger of death, electricity

Before opening the device housing, disconnect the power supply to the device and make sure it cannot be switched back on.



Chemical burn hazard

Wear eye protection.



Danger from chemicals

Wear protective gloves.



Danger from chemicals

Wear protective clothing.

- ▶ Flush lines several times (Initial flush).
- ▶ Empty water reservoir.
- ▶ Disconnect the water supply.



Important information!

Never cut hoses on or off the hose connector. Damaged connectors or sealing edges lead to leaks.

- ▶ Disconnect tubes to the canisters and to the washing machines.
- ▶ Open the connection box.
- ▶ Disconnect and remove all electrical cables.
- ▶ Unscrew the device from the wall.

✓ *The device is dismantled.*

Proper disposal

Dispose of the device, packaging and replaced parts in accordance with the regulations applicable in the country where the device was installed.



The device must not be disposed of with household waste.

The device can be returned in accordance with the WEEE Directive 2012/19/EU.

For more information: <https://www.saier.eu/en/unternehmen/support>

20 Appendix

Nameplate

Note: The illustration shows a nameplate as an example. The information in the illustration is for explanatory purposes only and is not valid. The information in the chapter “Technical data” and on the product’s nameplate is binding.



- 1 SAIER / MPX logo
Note: Device is double-insulated
UKCA marking
Note: Do not dispose of device with household waste!
CE marking
- 2 Type designation
- 3 Serial number
- 4 Number of products
Number of machines
Flow rate
- 5 Operating voltage
Frequency specification
Power specification
Max. ambient temperature
- 6 Barcode



SAIER Dosiertechnik GmbH

Gewerbestrasse 71

79194 Gundelfingen

Germany

Phone +49 761 59252-0

Fax +49 761 58490-9

info@saier.eu



1005469